

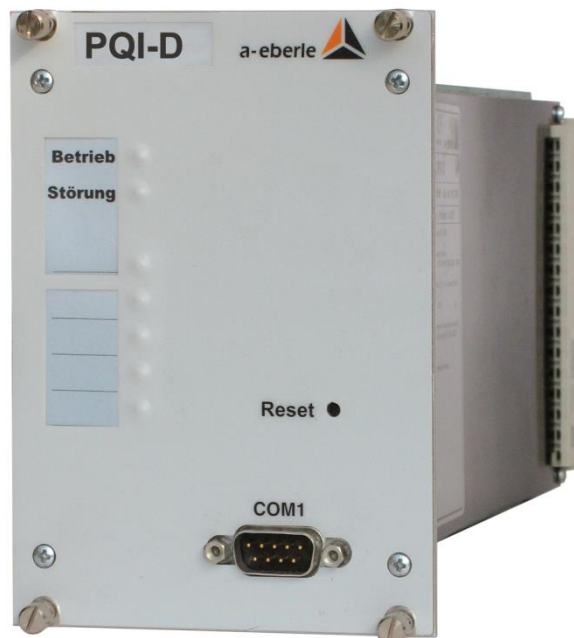

Operating manual

# Power Quality Interface



GB

PQI-D model



**Note:**

The current version of the operating manual is based on firmware versions > 4.0.05 (2x4xU) and > 5.0.11 (4xU, 4xI).

It is updated continuously.

For newer versions, either contact us directly or refer to the most recent version of the operating manual, available on our website ([www.a-eberle.de](http://www.a-eberle.de)).

**A. Eberle GmbH & Co. KG**

Frankenstraße 160

90461 Nuremberg, Germany

Telephone: 0911 / 62 81 08 0

Fax: 0911 / 62 81 08 96

E-mail: [info@a-eberle.de](mailto:info@a-eberle.de)

Internet: [www.a-eberle.de](http://www.a-eberle.de)

**A. Eberle GmbH & Co. KG** cannot be held liable for any damage or losses resulting from printing errors or changes to this operating manual.

Furthermore, **A. Eberle GmbH & Co. KG** does not assume responsibility for any damage or losses resulting from defective devices or from devices altered by the user.

**Copyright 2012 by A. Eberle GmbH & Co. KG.**

Subject to change.

## Contents

---

<b>1.</b>	<b>Safety information .....</b>	<b>8</b>
1.1	Electrical safety .....	8
1.2	Mounting.....	9
<b>2.</b>	<b>Technical concept.....</b>	<b>10</b>
2.1	Application .....	10
2.2	PQI-D Power Quality Interface features .....	12
2.3	Description .....	13
<b>3.</b>	<b>Fault recorder .....</b>	<b>14</b>
3.1	Event recorder .....	14
3.2	Oscilloscope, r.m.s. value recorder.....	15
3.2.1	Trigger conditions .....	15
3.2.2	External trigger.....	16
3.2.3	Fault record: pre-trigger and re-trigger time.....	17
3.2.4	Oscilloscope recorder .....	18
3.2.5	R.m.s. value recorder .....	19
3.3	Signal voltage recorder .....	20
3.4	Harmonic recorder.....	21
<b>4.</b>	<b>Technical data.....</b>	<b>22</b>
4.1	Regulations and standards.....	22
4.2	Voltage inputs .....	23
4.3	Current inputs .....	24
4.4	Analogue outputs.....	25
4.5	Binary inputs .....	26
4.6	Binary outputs (BO).....	26
4.7	Limit value monitoring.....	27
4.8	Overview of measurement quantities .....	27
4.8.1	Deduced measurement quantities: .....	28
4.8.2	Statistical quantities:.....	31
4.8.3	Overview of events: .....	32
4.8.4	Overview of binary message signals, 4xU and 4xI .....	39
4.8.5	Device 8 x U.....	42
4.9	Reference conditions .....	49
4.10	Measurement data acquisition .....	49
4.11	Data memory .....	49

4.12	Electromagnetic compatibility .....	50
4.13	Electrical safety .....	51
4.14	Operating voltages.....	51
4.15	Power supply .....	51
4.16	Binary inputs and outputs, analogue outputs .....	52
4.17	Environmental conditions.....	53
<b>5.</b>	<b>Mechanical design.....</b>	<b>54</b>
5.1	Plug-in module .....	54
5.2	Housing .....	54
5.3	Assignment of socket connectors 1 ... 5 .....	58
5.3.1	Socket connector 1 .....	58
5.3.2	Socket connector 2 .....	58
5.3.3	Socket connector 3 - feature C20 ... C31 .....	62
5.3.4	Socket connector 4 .....	62
5.3.5	Socket connector, 5 interfaces .....	69
5.4	Block diagrams .....	71
5.4.1	Block diagram feature C10 / M00, M96 .....	71
5.4.2	Block diagram feature C20...C31 / M92.....	71
5.4.3	Block diagram feature C20...C31 / M93.....	72
5.4.4	Block diagram feature C20...C31 / M94.....	72
5.4.5	Block diagram feature C20...C31 / M95.....	72
5.4.6	Block diagram feature C40...C41, M97, M98.....	73
<b>6.</b>	<b>Serial interfaces.....</b>	<b>73</b>
6.1	RS232 interfaces .....	74
6.2	RS485 interfaces .....	74
6.3	E-LAN (Energy - Local Area Network) .....	74
6.3.1	Features .....	74
6.3.2	Operation.....	75
6.4	COM3 .....	77
6.5	Time and trigger bus.....	78
6.6	Time synchronisation.....	78
6.6.1	RS232 interface of the time master (COM): .....	78
6.6.2	Time synchronisation bus (RS485):.....	78
6.7	External trigger .....	80
<b>7.</b>	<b>Voltage quality monitor.....</b>	<b>81</b>
7.1	Standard analysis .....	81

7.1.1	Overview EN50160 (2010) .....	82
7.1.2	Characteristics of the voltage supply .....	83
7.2	Network quality events .....	87
7.2.1	Interval events .....	88
7.2.2	Start / stop events.....	89
7.2.3	Prioritising events .....	90
7.3	Flagging .....	91
7.3.1	Binary event notification signals.....	91
7.3.2	Aggregation of statistical values .....	92
7.3.3	Monitoring statistical values.....	92
7.3.4	Controlling the event evaluation .....	93
7.4	Basic setting for PQI-D .....	93
<b>8.</b>	<b>Measurement circuits.....</b>	<b>94</b>
8.1	Connection possibilities .....	94
8.2	Current transformer connections.....	95
8.2.1	PQI-D current transformer connection.....	96
8.3	Voltage transformer connections .....	97
8.3.1	Voltage transformer connection PQI-D .....	98
8.4	Reference voltage .....	99
8.5	Network frequency .....	99
8.6	System time .....	99
8.7	Binary inputs .....	100
8.8	Binary outputs.....	100
8.9	Analogue outputs.....	100
8.10	Analogue inputs .....	101
8.11	LED display .....	101
8.12	Synchronisation of interval average power values.....	101
<b>9.</b>	<b>Data management.....</b>	<b>102</b>
9.1	Measurement data classes .....	102
9.2	Memory configuration .....	103
<b>10.</b>	<b>Definition of the measurement quantities .....</b>	<b>105</b>
10.1	Sampling values .....	105
10.2	Half-period values .....	105
10.2.1	R.m.s. values .....	106
10.2.2	Synchronised sampling values .....	106
10.2.3	10/12-period values.....	107

10.2.4	150/180-period values.....	107
10.2.5	10-minute values .....	108
10.2.6	2-hour values .....	108
10.3	Sampling values .....	109
10.3.1	Primary sampling values .....	109
10.3.2	Phase-to-phase sampling values.....	109
10.4	R.m.s. voltage values .....	110
10.5	Negative deviation, positive deviation .....	111
10.6	R.m.s. current values .....	111
10.7	Network frequency.....	111
10.8	Spectral analysis.....	111
10.8.1	R.m.s. values of the harmonic subgroups.....	111
10.8.2	R.m.s. values of the interharmonic subgroups.....	112
10.8.3	Harmonic distortions .....	112
10.8.4	Signal voltage.....	114
10.8.5	Phase of the voltages, currents to reference voltage (fundamental oscillation) .....	114
10.8.6	Phase of the phase voltages to associated conductor currents (fundamental oscillation)..	114
10.8.7	Phase of the current harmonics to the phase voltage fundamental oscillation .....	114
10.9	Symmetrical components, asymmetries, phase sequence .....	115
10.10	Power measurement quantities .....	117
10.10.1	Active powers .....	117
10.10.2	Apparent power.....	119
10.10.3	Reactive power .....	121
10.10.4	Dimensionless power measurement quantities.....	123
10.10.5	Active energies.....	126
10.10.6	Reactive energies.....	126
10.11	Flicker magnitude .....	127
<b>11.</b>	<b>Transnestic.....</b>	<b>128</b>
<b>12.</b>	<b>Updating the firmware .....</b>	<b>129</b>
<b>13.</b>	<b>Maintenance and current consumption .....</b>	<b>131</b>
13.1	Changing the fuse .....	131
13.2	Changing the battery .....	131
13.3	PQI-D current consumption.....	132
<b>14.</b>	<b>Scope of delivery .....</b>	<b>133</b>
<b>15.</b>	<b>Storage information .....</b>	<b>133</b>
<b>16.</b>	<b>Guarantee.....</b>	<b>Fehler! Textmarke nicht definiert.</b>

17.      **Ordering information .....134**

## Safety information

---

### Electrical safety



Before you begin to commission the device, you should be aware of some of the dangers that may occur if the device is used improperly.

- ▶ **The PQI-D is a device with degree of protection I. Before it is connected to the voltage, it must first be connected to the system's earthing system via its protective earth connection.**
- ▶ **The connected circuits must not exceed the protection category of the device (e.g. measurement inputs: CAT III / 300 V).**
- ▶ **The device must not be used in circuits that contain corona discharges.**
- ▶ **The device must be removed from the network immediately if it is determined that the device can no longer be operated safely due to a mechanical or electrical fault.**
- ▶ **Please note: if the Power Quality Interface is installed in a housing, the secondary circuits of the current transformer must be short-circuited before the terminal connections of the current transformers are removed from the device. Devices in 19" enclosures are protected against short circuits via a device built in to the terminal block. The modules can be plugged in and withdrawn at will, without having to short-circuit the current transformer(s) first.**
- ▶ **Please note that there is a danger to life wherever a voltage of > 50 V r.m.s. is present.**



## Mounting



The operational safety of the device can only be ensured when the electrical connection data of the device supplied match the requirements which apply at the installation location.

Please check the following parameters against the type plate:

▶ **Auxiliary voltage input: Supply voltage range**

AC nominal range	100V ... 240V	-
AC operating range	90 ... 264 V	
DC nominal range	100 ... 300 V	20 ... 70 V
DC operating range	100 ... 300 V	18 ... 72 V

▶ **Current measurement inputs: max. continuous current/input voltage**

C20; C21	:	5A
C30, C31	:	10A
C40, C41	:	230 mV RMS

▶ **Voltage measurement inputs: max. conductor-to-earth voltage**

E1	:	200 V AC
E2	:	460 V AC
E9	:	200 V AC, 460 V AC

▶ **Binary inputs: Maximum input voltage**

Mxx.0:	48...250 V AC/DC
Mxx.1:	10...48 V DC

## Technical concept

---

### Application

The state-of-the-art PQI-D power quality interface for medium and high voltage networks is the central component of a system for carrying out all of the required measurement tasks in electrical networks. The PQI-D can be used as both a power quality interface compliant with DIN EN 50160 and as a measurement device for measuring all physically-defined measurement quantities in AC electrical networks.

The component is primarily designed to monitor special reference quantities and quality agreements between the energy supplier and the customer, as well as to record, analyse and save the data.

Modern voltage quality measurement devices operate according to the IEC 61000-4-30 standard. This standard defines measurement methods and so provides the user with a basis for comparison. Devices from different manufacturers which function in accordance with this standard must provide the same measurement results.

The standard defines two measuring device classes.

Class A measuring devices are used primarily for measurements related to contracts in the customer/supplier relationship, while Class B measuring devices can be used for determining statistical quality values.

The PQI-D complies with the requirements of IEC 61000-4-30 (2008) for class A devices for all parameters.

▶ Parameter	Class
● Accuracy of voltage measurement	A
● Determination of time intervals	A
● Marking of measurement values for events	A
● Harmonics, interharmonics	A
● Flicker	A
● Frequency	A
● Voltage asymmetry	A
● Recording of events	A
● Synchronisation	A

Five procedures are available for event-triggered fault recording:

The **event recorder** stores the messages that denote the type, time and properties of events in chronological order.

The **oscilloscope recorder** stores the sampling values of fault events with pre-event and post-event history.

The **r.m.s. recorder** stores the half-period r.m.s. values of fault events with pre-event and post-event history.

The **signal voltage recorder** stores the 10/12-period r.m.s. values of an adjustable frequency range (e.g. ripple-control frequency).

The **harmonic recorder** stores the 10-minute spectrum of the harmonics from the 2nd to 50th harmonic for voltages and currents.

All fault records are triggered by an event or combination of events which can be freely defined. This enables phase-phase and phase-earth events to be recorded simultaneously.

Event messages (e.g. limit value violations) can also be signalled directly via relays if required.

The device has two RS232 interfaces (COM 1 and COM 2) and two E-LAN (Energy Local Area Network) system/transport bus interfaces, which can be used to network up to 255 REGSys™ devices (e.g. REG-D / EOR-D).

WinPQ and WinPQ Para Express are available as PC programs.

It supports the parameterisation, download and time-constant backup of measurement data in a database on the PC.

The measurement data can be accessed continuously, cyclically or once only by the device.

Both offline data (from the database) and online data (from the device) can be displayed.

A button protected against unintentional touching is provided for firmware updates.

The device is available in several different versions.

Current inputs are available for the measurement circuit (C20, C30) and for the protective circuit (C21, C31).

The following input configurations can be selected:

- 4 voltage transformers for conventional power quality applications (feature C00)
- 8 voltage transformers for power quality applications in double busbar systems (feature C10)
- 4 voltage transformers and 4 current transformers for power quality and general measurement tasks.

If the PQI-D is supplied in a 20TE or 30TE housing, the desired number and type of inputs and outputs on the terminal strip must be specified.

The version should be specified since the plug-in module offers a wide range of different inputs and outputs, but the options for connecting terminals are limited.

## PQI-D Power Quality Interface features

- Measuring the voltage quality according to DIN EN 50160
- Class A device according to IEC 61000- 4-30
- 10.24 kHz sampling frequency
- Fault recorder function up to  $20 \cdot$  nominal current ( $100 \times I_n$ )
- Phase-phase and phase-earth measurements are possible simultaneously
- Voltage measurement channels for  $U_{12}$ ,  $U_{23}$ ,  $U_{31}$ ,  $U_{NE}$
- Additional measurement of currents  $I_1$ ,  $I_2$ ,  $I_3$ ,  $I_0$
- Determination of over 3000 measurement values
- Freely programmable limit values and outputs using isolated contacts
- Five freely programmable LEDs
- Freely programmable binary inputs to start and stop measurements remotely
- Adoption of conventional measurement transducer functions; up to eight measurement quantities can be chosen and output via an mA signal.
- Analysis of the data via a MySQL-supported database with the help of the WinPQ software package
- Connection to the control system according to IEC 870-5-103
- Connection to the control system according to IEC 61850

## Description

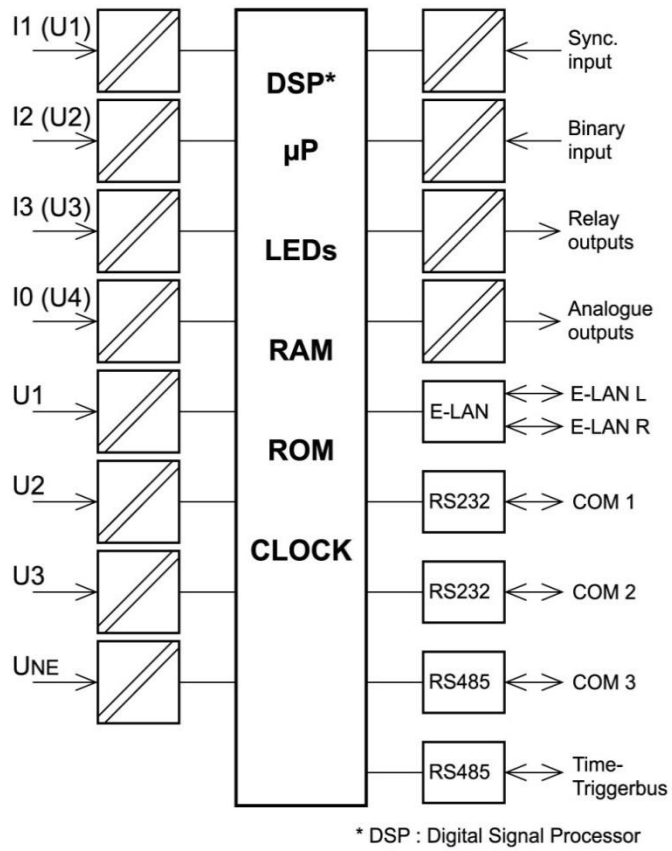

*Power Quality Interface function*

We take care of it.

## Fault recorder

## Event recorder

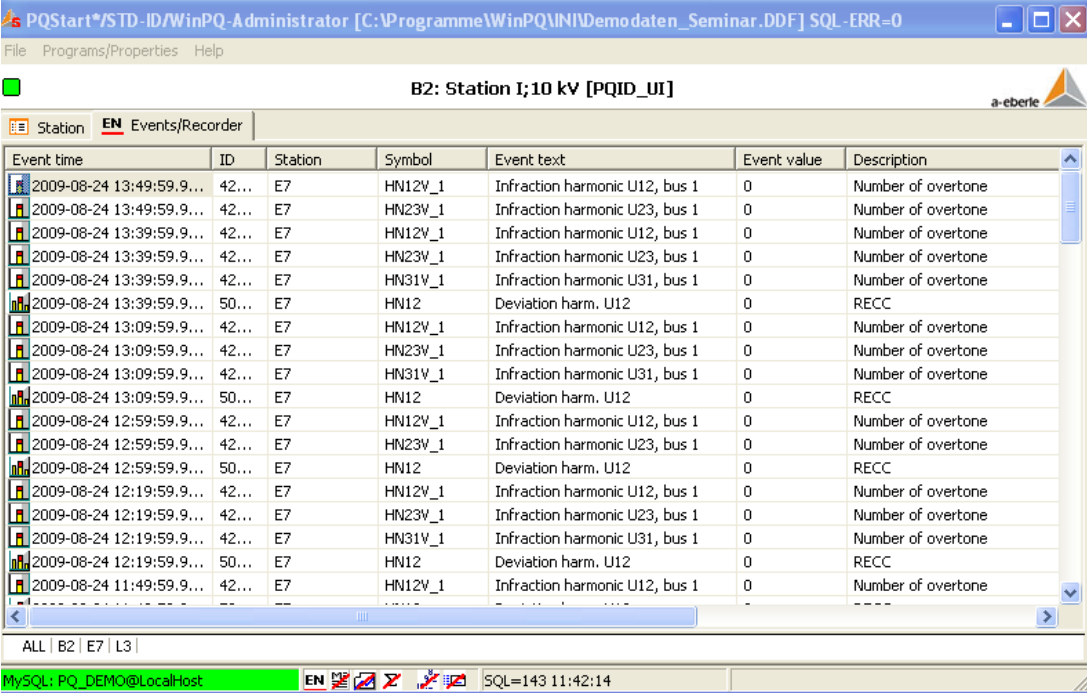

Event time	ID	Station	Symbol	Event text	Event value	Description
2009-08-24 13:49:59.9...	42...	E7	HN12V_1	Infraction harmonic U12, bus 1	0	Number of overtone
2009-08-24 13:49:59.9...	42...	E7	HN23V_1	Infraction harmonic U23, bus 1	0	Number of overtone
2009-08-24 13:39:59.9...	42...	E7	HN12V_1	Infraction harmonic U12, bus 1	0	Number of overtone
2009-08-24 13:39:59.9...	42...	E7	HN23V_1	Infraction harmonic U23, bus 1	0	Number of overtone
2009-08-24 13:39:59.9...	42...	E7	HN31V_1	Infraction harmonic U31, bus 1	0	Number of overtone
2009-08-24 13:39:59.9...	50...	E7	HN12	Deviation harm. U12	0	RECC
2009-08-24 13:09:59.9...	42...	E7	HN12V_1	Infraction harmonic U12, bus 1	0	Number of overtone
2009-08-24 13:09:59.9...	42...	E7	HN23V_1	Infraction harmonic U23, bus 1	0	Number of overtone
2009-08-24 13:09:59.9...	42...	E7	HN31V_1	Infraction harmonic U31, bus 1	0	Number of overtone
2009-08-24 13:09:59.9...	50...	E7	HN12	Deviation harm. U12	0	RECC
2009-08-24 12:59:59.9...	42...	E7	HN12V_1	Infraction harmonic U12, bus 1	0	Number of overtone
2009-08-24 12:59:59.9...	42...	E7	HN23V_1	Infraction harmonic U23, bus 1	0	Number of overtone
2009-08-24 12:59:59.9...	50...	E7	HN12	Deviation harm. U12	0	RECC
2009-08-24 12:19:59.9...	42...	E7	HN12V_1	Infraction harmonic U12, bus 1	0	Number of overtone
2009-08-24 12:19:59.9...	42...	E7	HN23V_1	Infraction harmonic U23, bus 1	0	Number of overtone
2009-08-24 12:19:59.9...	42...	E7	HN31V_1	Infraction harmonic U31, bus 1	0	Number of overtone
2009-08-24 12:19:59.9...	50...	E7	HN12	Deviation harm. U12	0	RECC
2009-08-24 11:49:59.9...	42...	E7	HN12V_1	Infraction harmonic U12, bus 1	0	Number of overtone

The event recorder stores the messages that denote the type, time and properties of events in chronological order.

All events have the same data structure and contain the following components

- Time stamp : Time at which the event occurred
- Identifier : Type of event
- Event value : Specific magnitude of event

All relevant system processes are registered in events.

The event recorder can be seen as a log book that provides a central, quick history overview for all procedures with minimal memory requirements. These include messages that refer to detailed records for fault events, for example.

The user can apply a configurable event filter to select the messages that are to be stored.

## Oscilloscope, r.m.s. value recorder

The oscilloscope recorder of the PQI-D is also referred to as recorder A, and the r.m.s. value recorder as recorder B.

### Trigger conditions

The central trigger uses the various measurement quantities and associated thresholds to generate corresponding binary trigger signals, which are evaluated using the individual trigger masks of recorders A, B and the external trigger to activate the triggering.

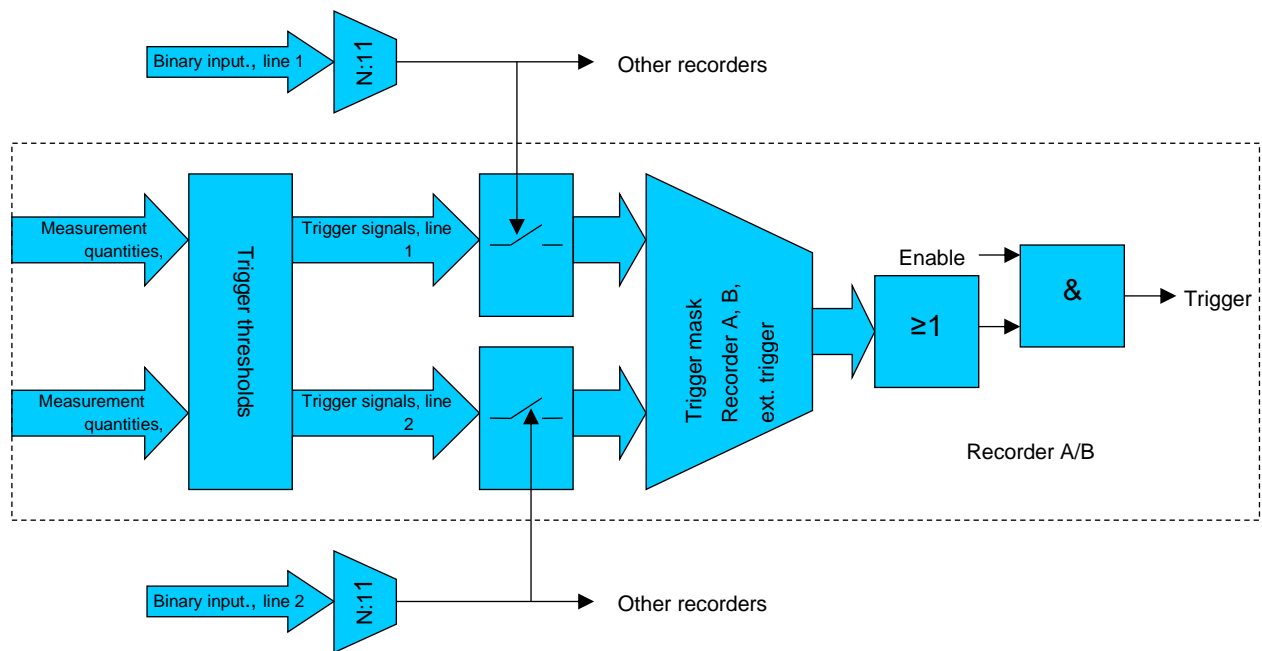

Voltage trigger signals:

Designation	$U_{LE/N}$	$U_{NE}$	$U_L$
Lower limit for half-period r.m.s. values	✓		✓
Upper limit for half-period r.m.s. values	✓	✓	✓
Jump in half-period r.m.s. values	✓	✓	✓
Jump in half-period phases	✓		
Envelope curve trigger sampling values	✓	✓	✓
Lower limit of symmetrical components, half-period values	Positive-sequence system		
Upper limit of symmetrical components, half-period values	Positive/negative/zero-sequence system		

Current trigger signals (4xU, 4xI only):

Designation	I <sub>L</sub>	I <sub>E/N</sub>
Lower limit for half-period r.m.s. values	✓	
Upper limit for half-period r.m.s. values	✓	✓
Jump in half-period r.m.s. values	✓	✓

Frequency trigger signals:

Designation
Lower limit for half-period frequency
Upper limit for half-period frequency
Jump in half-period frequency

Binary trigger signals:

Designation
External trigger
Binary inputs (debounced) rising/falling edge
Software triggers

## External trigger

When a trigger signal becomes active, this signal is enabled in the trigger mask of the external trigger and the output of the external trigger is enabled, a trigger pulse of a adjustable length is sent to the trigger bus, where it can be received by other devices and, at the same time, trigger recorders A and B.



## Fault record: pre-trigger and re-trigger time

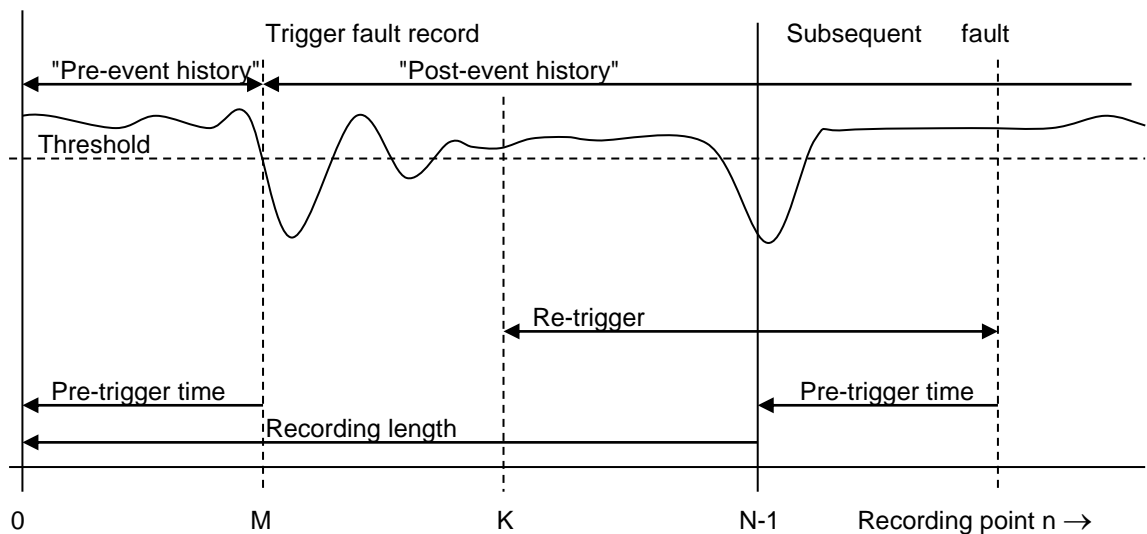

$N$  = number of recording points

Trigger point  $M$  = index of the first recording point after triggering with  $0 < M < N-1$

Re-trigger point  $K$  = index of first recording point that can trigger a follow-up fault record with  $M < K < M + N-1$

The number of recording points per fault record can be set for each recorder,

as can the position of the pre-trigger point in relation to the first recording point.

The pre-trigger point corresponds to the time of triggering. Correspondingly, the time prior to this is referred to as the pre-event history, the time after it as the post-event history, and the relevant fault record as the trigger fault record. The cause of the trigger is also recorded.

Using a second trigger point, the re-trigger point, repeated triggering can be used to generate follow-up fault records of the same length which, together with the trigger fault record, form a seamless and non-overlapping fault record sequence. The maximum number of follow-up fault records is adjustable.

The following rules apply to the re-trigger point function:

- The re-trigger point may lie between the pre-trigger point and the pre-trigger time after the end of a fault record.
- Trigger fault records can be re-triggered between the re-trigger point and the pre-trigger time after the end of a fault record.
- Follow-up fault records can be re-triggered up to the pre-trigger time after the end of a fault record.
- If the re-trigger point is located on the pre-trigger point, triggering forces the maximum number of follow-up fault records to be recorded, independently of the re-trigger events.

We take care of it.

## Oscilloscope recorder

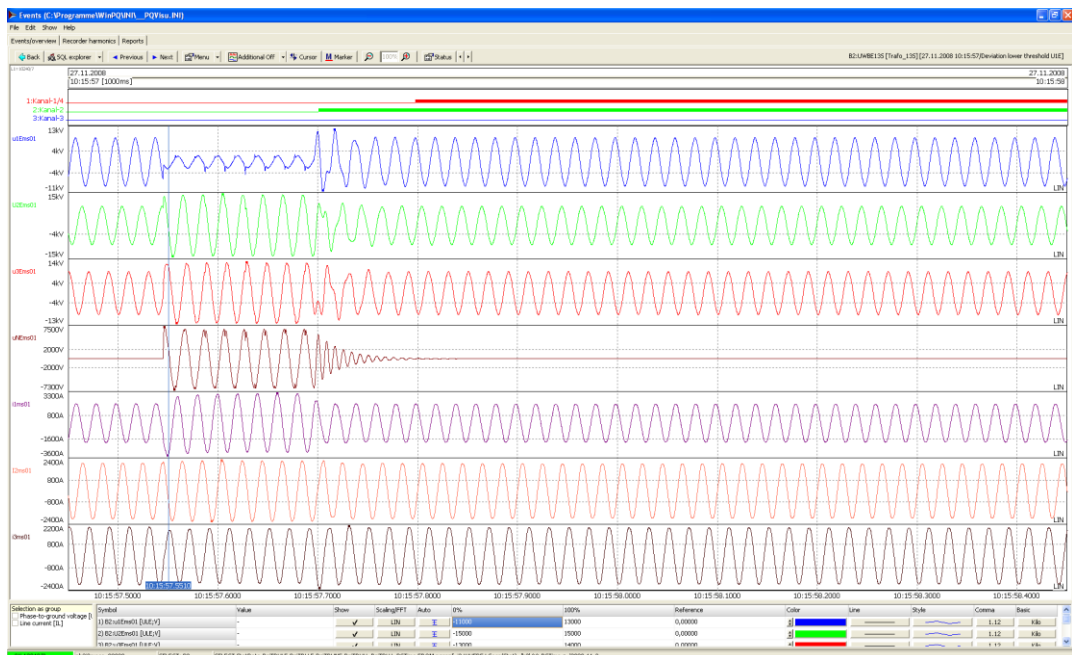

### Recorder A

Recorder A records the sampling values for a selection of measured and phase-to-phase voltages ( $u_{1E}$ ,  $u_{2E}$ ,  $u_{3E}$ ,  $u_{NE}$ ,  $u_{12}$ ,  $u_{23}$ ,  $u_{31}$ ) and currents ( $i_1$ ,  $i_2$ ,  $i_{3E}$ ,  $i_N$ , version 4xU and 4xI only) with a fixed sampling frequency of 10.24kHz.

The maximum fault record length is 20480 sampling points, i.e. 2s.

The device can store a maximum of 512 fault records.

The available memory for this is ~28 MB.

## R.m.s. value recorder

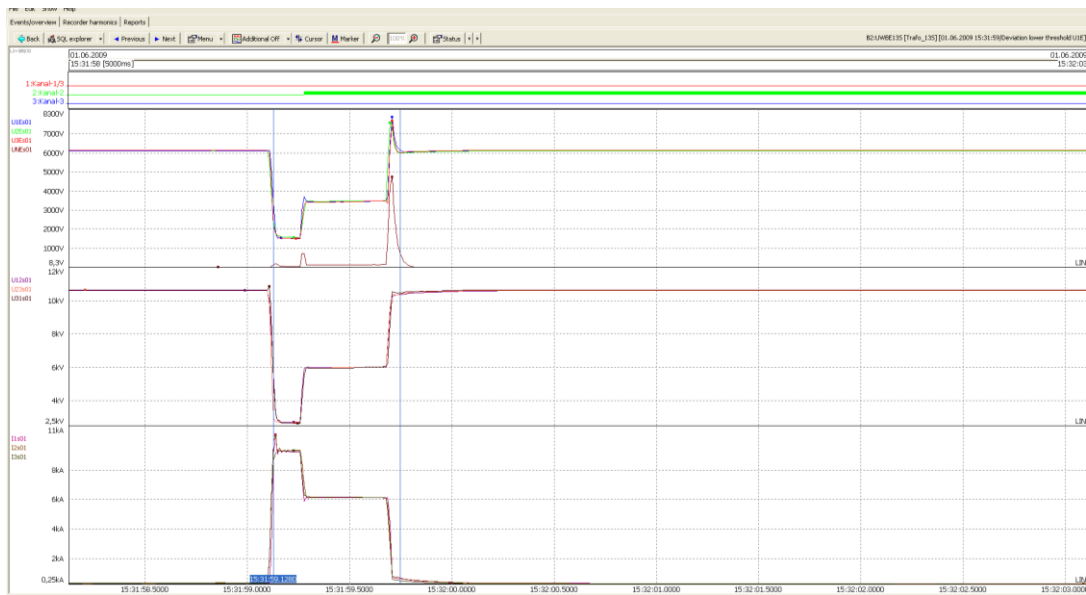

### Recorder B

Recorder B records the half-period values for a selection of the following measurement quantities:

Symbol	Designation
$U_{1E-1/2} / U_{1N-1/2}$	R.m.s. value of voltage at outer conductor L1 – earth/neutral conductor
$U_{2E-1/2} / U_{2N-1/2}$	R.m.s. value of voltage at outer conductor L2 – earth/neutral conductor
$U_{3E-1/2} / U_{3N-1/2}$	R.m.s. value of voltage at outer conductor L3 – earth/neutral conductor
$U_{NE-1/2}$	R.m.s. value of neutral earth voltage
$U_{12-1/2}$	R.m.s. value of voltage at outer conductor L1 – outer conductor L2
$U_{23-1/2}$	R.m.s. value of voltage at outer conductor L2 – outer conductor L3
$U_{31-1/2}$	R.m.s. value of voltage at outer conductor L3 – outer conductor L1

$I_{1-1/2}$	R.m.s. value of conductor current L1 (versions 4xu and 4xl only)
$I_{2-1/2}$	R.m.s. value of conductor current L2 (versions 4xu and 4xl only)
$I_{3-1/2}$	R.m.s. value of conductor current L3 (versions 4xu and 4xl only)
$I_{E/N-1/2}$	R.m.s. value of sum current/conductor current N (versions 4xu and 4xl only)
$P_{\Sigma(1/2)}$	Active power with sign (versions 4xu and 4xl only)
$Q_{\Sigma(1/2)}$	Reactive power with sign of displacement reactive power (versions 4xu and 4xl only)
$S_{\Sigma(1/2)}$	Apparent power (versions 4xu and 4xl only)
$f_{1/2}$	Network frequency

The maximum fault record length is 12000 sampling points, i.e. ~2 min.

The device can store a maximum of 512 fault records.

The memory available for this is ~16 MB.

## Signal voltage recorder

The signal voltage recorder of the PQI-DA is also referred to as recorder S.

It stores the 10/12-period r.m.s. values for a selection of the signal voltages ( $U_{S1E/N}$ ,  $U_{S2E/N}$ ,  $U_{S3E/N}$ ,  $U_{SNE}$ ,  $U_{S12}$ ,  $U_{S23}$ ,  $U_{S31}$ ) without pre-event history.

Triggering takes place when at least one of the 7 signal voltages has exceeded the adjustable threshold.

The maximum fault record length is 3000 sampling points, i.e. ~10min.

The device can store a maximum of 512 fault records.

The memory available for this is ~4 MB.

## Harmonic recorder

When the harmonic limits or the THD (10-min values) of a voltage are exceeded, the harmonic recorder stores the corresponding harmonic spectra (10-min values) for a selection of voltages and currents with an adjustable number of harmonics ( $\leq 49$ ), starting with the 2nd harmonic.

The trigger events can be selected from the corresponding EN50160 events according to error type (harmonic/THD) and measurement voltage ( $U_{1E/N}$ ,  $U_{2E/N}$ ,  $U_{3E/N}$ ,  $U_{12}$ ,  $U_{23}$ ,  $U_{31}$ ).

The trigger condition is created by linking selected events together with OR connections. Alternatively, recording can be set to take place continuously.

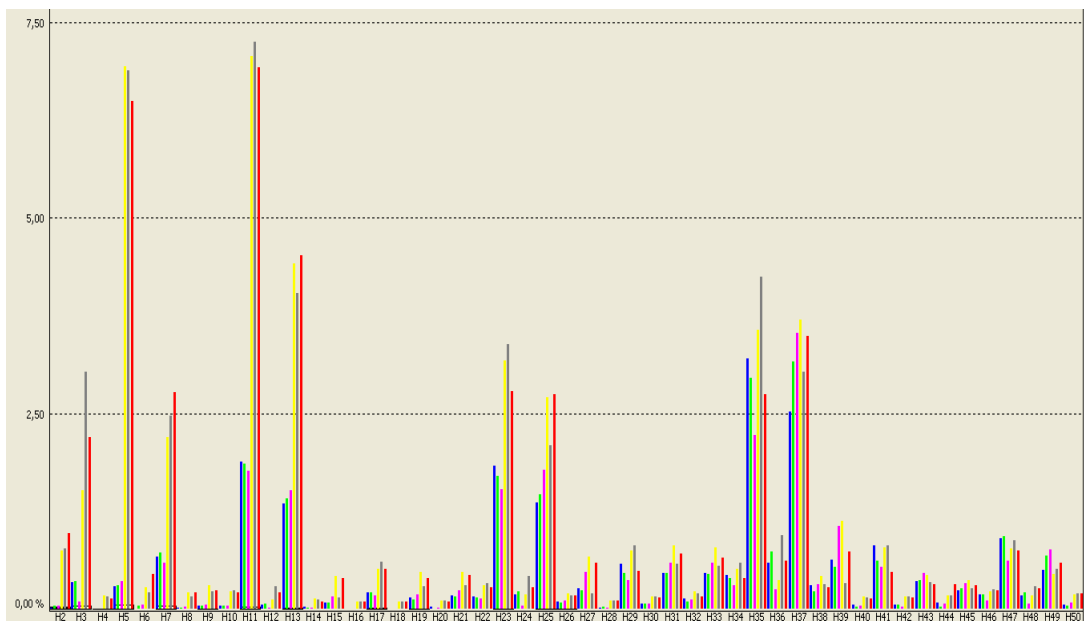

*Example: Harmonic recorder*

## Technical data

---

### Regulations and standards

IEC 61010-1	/ DIN EN 61010-1
IEC 60255-4	/ DIN EN 60255-4
IEC 61326-1	/ DIN EN 61326-1
IEC 60529	/ DIN EN 60529
IEC 60068-1	/ DIN EN 60068-1
IEC 60688	/ DIN EN 60688
IEC 61000-6-2	/ DIN EN 61000-6-2
IEC 61000-6-4	/ DIN EN 61000-6-4
IEC 61000-6-5	/ DIN EN 61000-6-5
IEC 61000-4-30	/ DIN EN 61000-4-30
IEC 61000-4-7	/ DIN EN 61000-4-7
IEC 61000-4-15	/ DIN EN 61000-4-15
IEC 61000-3-3	/ DIN EN 61000-3-3
	DIN EN 50160

## Voltage inputs

	E1	E2
$U_n$	100 V AC	230 V AC
Measurement range, sine	200 V AC	460 V AC
Input impedance	360 k $\Omega$	810 k $\Omega$
Isolation	CAT III / 300 V	
Bandwidth	DC...3 kHz	
<b>Measurement quantity</b>	<b>Error limits (IEC 61000-4-30, Class A)</b>	
Fundamental oscillation: r.m.s.	$\pm 0.1\%$ of $U_{din}$ over 10% ~ 150% of $U_{din}$	
Fundamental oscillation: Phase	$\pm 0.15^\circ$ over 50% ~ 150% of $U_{din}$ over $f_{nom} \pm 15\%$	
2nd ... 50th harmonic	$\pm 5\%$ of display over $U_m = 1\% \sim 16\%$ of $U_{din}$ $\pm 0.05\%$ of $U_{din}$ over $U_m < 1\%$ of $U_{din}$	
2nd .... 49th interharmonic	$\pm 5\%$ of display over $U_m = 1\% \sim 16\%$ of $U_{din}$ $\pm 0.05\%$ of $U_{din}$ over $U_m < 1\%$ of $U_{din}$	
Frequency	$\pm 5\text{mHz}$ over $f_{nom} \pm 15\%$ ( $f_{nom} = 50\text{ Hz} / 60\text{ Hz}$ )	
Flicker, Pst, Plt	$\pm 5\%$ of display over 0.02% ~ 20% of $\Delta U / U$	
Dip residual voltage	$\pm 0.2\%$ of $U_{din}$ over 10% ~ 100% of $U_{din}$	
Dip duration	$\pm 20\text{ ms}$ over 10% ~ 100% of $U_{din}$	
Swell residual voltage	$\pm 0.2\%$ of $U_{din}$ over 100% ~ 150% of $U_{din}$	
Swell duration	$\pm 20\text{ ms}$ over 100% ~ 150% of $U_{din}$	
Interruption duration	$\pm 20\text{ ms}$ over 1% ~ 100% of $U_{din}$	
Voltage asymmetry	$\pm 0.15\%$ over 1% ~ 5% of display	
Ripple control voltage	$\pm 5\%$ of display over $U_m = 3\% \sim 15\%$ of $U_{din}$ $\pm 0.15\%$ of $U_{din}$ over $U_m = 1\% \sim 3\%$ of $U_{din}$	

## Current inputs

	C20	C21	C30	C31
In	1A		5A	
Measurement range, sine	$0 < I \leq 2A$	$0 < I \leq 20A$	$0 < I \leq 10A$	$0 < I \leq 100 A$
Input load	$< 0.1 V A$		$< 0.5 V A$	
Overload capacity, continuous $\leq 10 s$ $\leq 1 s$ $\leq 5 ms$	5 A 10 A 30 A 100 A	10 A 30 A 100 A 500 A		
Isolation	CAT III / 300 V			
<b>Measurement quantity</b>	<b>Error limits</b>			
Fundamental oscillation: r.m.s.	$\pm 0.1\%$ of end value over measurement range			$\pm 0.2\%$ of end value over measurement range
Fundamental oscillation: Phase	$\pm 0.15^\circ$ over 10% ~ 100%	$\pm 0.15^\circ$ over 5% ~ 50%	$\pm 0.15^\circ$ over 10% ~ 100%	$\pm 1.0^\circ$ over 5% ~ 10%
Bandwidth	25 Hz...3 kHz			
2nd...50th harmonic	$\pm 5\%$ of display over $I_m = 1\% \sim 16\%$ of $I_n$ $\pm 0.05\%$ of $I_n$ over $I_m < 1\%$ of $I_n$			$\pm 10\%$ of display over $I_m = 1\% \sim$ $16\%$ of $I_n \pm 0.1\%$ of $I_n$ $I_m < 1\%$ of $I_n$
2nd .... 49th interharmonic	$\pm 5\%$ of display over $I_m = 1\% \sim 16\%$ of $I_n$ $\pm 0.05\%$ of $I_n$ over $I_m < 1\%$ of $I_n$			$\pm 10\%$ of display over $I_m = 1\% \sim$ $16\%$ of $I_n \pm 0.1\%$ of $I_n$ over $I_m < 1\%$ of $I_n$



**Feature C40:** mV inputs for Rogowski coils

Input resistance	10 k $\Omega$
Full scale range	150 mV



**Note:**

In order to guarantee measurement accuracy, only Rogowski coils from A. Eberle GmbH & Co. KG should be used.

**Feature C41:** mV inputs for mini clamps

Input resistance	2 M $\Omega$
Full scale range	230 mV

## Analogue outputs

Refer to		ordering information for number
Output range	Y1...Y2	-20 mA...0...20 mA
		Y1 and Y2 programmable
Electrical isolation		Optocoupler
Load range		$0 \leq R \leq 8 \text{ V} / Y2$
Alternating component		<0.5 % of Y2

The outputs can be continuously short-circuited or operated open. All output connections are galvanically isolated from all other circuits.

## Binary inputs

<b>Mxx.0 range</b>	in the range 0 V...264 V AC/DC
H level	$\geq 48$ V
L level	$< 10$ V
Input resistance	108 k $\Omega$
<b>Mxx.1 range</b>	in the range 0 V...48 V AC/DC
H level	$\geq 10$ V
L level	$< 5$ V
Input resistance	6.8 k $\Omega$
Signal	DC/AC $< 100$ Hz
Sampling cycle time	4 ms
Debounce cycles	Adjustable in the range 0... 250 corresponds to 0...1.0 s
Electrical isolation	Optocoupler, E1, E2 earthed E3, E4 earthed

## Binary outputs (BO)

Update cycle time	100 ms
Dwell time	Adjustable in the range 0...4 ·10 <sup>6</sup> s
Electrical isolation	isolated from all device-internal potentials
Type of relay	changeover contact
Status, R2, R3	individually galvanically isolated
R4, R5	Earthed
Contact load	AC: 250 V, 5 A ( $\cos\varphi = 1.0$ ) AC: 250 V, 3 A ( $\cos\varphi = 0.4$ ) DC: 220 V, 150 W switching capacity
No. of switching operations	$\geq 1 \cdot 10^4$ electrical

## Limit value monitoring

Limit values	programmable
Response times	programmable
Alarm displays	LED programmable
Relay	programmable

## Overview of measurement quantities

Aggregation intervals:	½ sine wave
	10/12 cycles ( $f_{nom}=50/60\text{Hz}$ )
	150/180 cycles ( $f_{nom}=50/60\text{Hz}$ )
	5 / 6 / 6.67 / 7.5 / 10 / 12 / 15 / 20 / 30 min
	2 h
	Day, week, year

✓\* = calculated but not transferred cyclically; ✓ = calculated and transferred cyclically

Aggregation interval	½ cycle	10/12 cycles	150/180 cycles	10 min	2 h	4xU 4xI	2x 4xU
<b>Measurement quantities</b>							
R.m.s. values of $U_{1E/N}$ , $U_{2E/N}$ , $U_{3E/N}$ , $U_{NE}$ , $U_{12}$ , $U_{23}$ , $U_{31}$ , $U_{ref}$ : $U_{1E/N}$ , $U_{2E/N}$ , $U_{3E/N}$ , $U_{NE}$ , $U_{12}$ , $U_{23}$ , $U_{31}$ , $U_{ref}$	✓*	✓	✓	✓	✓	✓	2x
R.m.s. values of $i_1$ , $i_2$ , $i_3$ , $i_{E/N}$ : $i_1$ , $i_2$ , $i_3$ , $i_{E/N}$	✓*	✓	✓	✓	✓	✓	
Active powers of the phases: $P_1$ , $P_2$ , $P_3$		✓	✓	✓	✓	✓	
Frequency (fundamental oscillation): F	✓*	✓	✓	✓	✓	✓	✓
R.m.s. values of DC component and fundamental oscillation for each of measurement channels 1..8			✓			✓	✓

## Deduced measurement quantities:

Aggregation interval						4xU 4xI	2x 4xU
Measurement quantities	1/2 cycle	10/12 cycles	150/180 cycles	10 min	2 h		
Harmonic subgroups (n=1..50) of $u_{1E/N}, u_{2E/N}, u_{3E/N}, u_{NE}, u_{12}, u_{23}, u_{31}$ : $u_{1E/N-n}, u_{2E/N-n}, u_{3E/N-n}, u_{NE-n}, u_{12-n}, u_{23-n}, u_{31-n}$		✓*	✓	✓	✓	✓	2x
Harmonic subgroups (n=1..50) of $i_1, i_2, i_3, i_{E/N}$ : $i_{1-n}, i_{2-n}, i_{3-n}, i_{E-n}$		✓*	✓	✓	✓	✓	
Interharmonic subgroups (n=0..49) of $u_{1E/N}, u_{2E/N}, u_{3E/N}, u_{NE}, u_{12}, u_{23}, u_{31}$ : $u_{1E/N-n+0.5}, u_{2E/N-n+0.5}, u_{3E/N-n+0.5}, u_{NE-n+0.5}, u_{12-n+0.5}, u_{23-n+0.5}, u_{31-n+0.5}$		✓*	✓	✓	✓	✓	2x
Interharmonic subgroups (n=0..49) of $i_1, i_2, i_3, i_{E/N}$ : $i_{1-n+0.5}, i_{2-n+0.5}, i_{3-n+0.5}, i_{E-n+0.5}$		✓*	✓	✓	✓	✓	
R.m.s. values of ripple control signals on $u_{1E/N}, u_{2E/N}, u_{3E/N}, u_{NE}, u_{12}, u_{23}, u_{31}$ : $u_{s1}, u_{s2}, u_{s3}, u_{sN}, u_{s12}, u_{s23}, u_{s31}$		✓	✓			✓	2x
Directions of harmonic energy flow (n=1..32) on $L_1, L_2, L_3$ : $FD_{1-n}, FD_{2-n}, FD_{3-n}$		✓	✓	✓	✓	✓	
Total harmonic distortion (2nd..40th harmonic) of $u_{1E/N}, u_{2E/N}, u_{3E/N}, u_{NE}, u_{12}, u_{23}, u_{31}$ : $THD_{1E/N}, THD_{2E/N}, THD_{3E/N}, THD_{NE}, THD_{12}, THD_{23}, THD_{31}$		✓	✓	✓	✓	✓	2x
Partial weighted harmonic distortion (14th..40th harmonic) of $u_{1E/N}, u_{2E/N}, u_{3E/N}, u_{NE}, u_{12}, u_{23}, u_{31}$ : $PWHD_{1E/N}, PWHD_{2E/N}, PWHD_{3E/N}, PWHD_{NE}, PWHD_{12}, PWHD_{23}, PWHD_{31}$		✓	✓	✓	✓	✓	2x
Total harmonic distortion (2nd..40th harmonic) of $i_1, i_2, i_3, i_{E/N}$ : $THD_1, THD_2, THD_3, THD_{E/N}$		✓	✓	✓	✓	✓	
Partial weighted harmonic distortion (14th..40th harmonic) von $i_1, i_2, i_3, i_{E/N}$ : $PWHD_1, PWHD_2, PWHD_3, PWHD_{E/N}$		✓	✓	✓	✓	✓	
Total harmonic currents (2nd..40th harmonic) of $i_1, i_2, i_3, i_{E/N}$ : $THC_1, THC_2, THC_3, THC_{E/N}$		✓	✓	✓	✓	✓	
Partial odd harmonic currents (21st..39th harmonic) of $i_1, i_2, i_3, i_{E/N}$ : $PHC_1, PHC_2, PHC_3, PHC_{E/N}$		✓	✓	✓	✓	✓	
K factors of $i_1, i_2, i_3, i_{E/N}$ : $k_1, k_2, k_3, k_{E/N}$		✓	✓	✓	✓	✓	
Average value of $I_1, I_2, I_3$ with sign(P): $I_M$		✓	✓	✓	✓	✓	
Collective active power: $P_\Sigma$		✓	✓	✓	✓	✓	
Apparent powers of the phases: $S_1, S_2, S_3$		✓	✓	✓	✓	✓	
Collective apparent power according to DIN 40110: $S_\Sigma$		✓	✓	✓	✓	✓	
Reactive powers of the phases (with sign): $Q_1, Q_2, Q_3$		✓	✓	✓	✓	✓	
Collective reactive power (DIN 40110): $Q_\Sigma$		✓	✓	✓	✓	✓	
Current distortion reactive power of the phases: $D_1, D_2, D_3$		✓	✓	✓	✓	✓	

Aggregation interval							
Measurement quantities	½ cycle	10/12 cycles	150/180 cycles	10 min	2 h	4xU 4xI	2x 4xU
Collective current distortion reactive power: $D\Sigma$		✓	✓	✓	✓	✓	
Active power of the fundamental oscillation: $P_G$	✓*	✓	✓	✓	✓	✓	
Apparent power of the geometrical fundamental oscillation: $S_G$	✓*	✓	✓	✓	✓	✓	
Displacement reactive power of the fundamental oscillation (with sign): $Q_{V-1}$	✓*	✓	✓	✓	✓	✓	
Phase angle of geometric apparent power of the fundamental oscillation $S_G$ : $\varphi_G$		✓	✓	✓	✓	✓	
Total active energies of the phases: $W_{t1}, W_{t2}, W_{t3}$		✓*	✓	✓	✓	✓	
Collective total active energy: $W_t$		✓*	✓	✓	✓	✓	
Drawn active energies of the phases: $W_{o1}, W_{o2}, W_{o3}$		✓*	✓	✓	✓	✓	
Collective drawn active energy: $W_o$		✓*	✓	✓	✓	✓	
Supplied active energies of the phases: $W_{i1}, W_{i2}, W_{i3}$		✓*	✓	✓	✓	✓	
Collective supplied active energy: $W_i$		✓*	✓	✓	✓	✓	
Total reactive energies of the phases: $W_{rt1}, W_{rt2}, W_{rt3}$		✓*	✓	✓	✓	✓	
Collective total reactive energy: $W_{rt}$		✓*	✓	✓	✓	✓	
Drawn (inductive) reactive energies of the phases: $W_{ro1}, W_{ro2}, W_{ro3}$		✓*	✓	✓	✓	✓	
Drawn (inductive) collective reactive energy: $W_{ro}$		✓*	✓	✓	✓	✓	
Supplied (inductive) reactive energies of the phases: $W_{ri1}, W_{ri2}, W_{ri3}$		✓*	✓	✓	✓	✓	
Supplied (inductive) collective reactive energy: $W_{ri}$		✓*	✓	✓	✓	✓	
Active powers of phase intervals (events): $P_{I1}, P_{I2}, P_{I3}$		✓				✓	
Collective active power of phase interval (event): $P_I$		✓				✓	
Active factors with sign: $PF_1, PF_2, PF_3, PF$			✓	✓	✓	✓	
Reactive factors with sign: $QF_1, QF_2, QF_3, QF$			✓	✓	✓	✓	
$\cos\varphi$ with sign: $\cos\varphi_1, \cos\varphi_2, \cos\varphi_3, \cos\varphi$			✓	✓	✓	✓	
$\sin\varphi$ with sign: $\sin\varphi_1, \sin\varphi_2, \sin\varphi_3, \sin\varphi$			✓	✓	✓	✓	
$\tan\varphi$ with sign: $\tan\varphi_1, \tan\varphi_2, \tan\varphi_3, \tan\varphi$			✓	✓	✓	✓	
Capacitive-inductive representation of $\cos\varphi$ (-1..0..+1): $Y_1, Y_2, Y_3, Y$			✓	✓	✓	✓	
$\cos\varphi$ with sign of displacement angle: $\text{COSPHV}_1, \text{COSPHV}_2, \text{COSPHV}_3, \text{COSPHV}$			✓	✓	✓	✓	
Voltage-current phase difference (fundamental oscillation): $\varphi_{1-1}, \varphi_{2-1}, \varphi_{3-1}$		✓	✓	✓	✓	✓	
Current-harmonic phase difference ( $n=2nd..40th$ ) on $L_1, L_2, L_3$ in relation to fundamental oscillation of the corresponding phase voltage: $\varphi_{1-n}, \varphi_{2-n}, \varphi_{3-n}$			✓	✓	✓	✓	
Voltage/reference voltage phase difference (fundamental oscillation) of $U_{1E/N}, U_{2E/N}, U_{3E/N}, U_{NE}, U_{12}, U_{23}, U_{31}$ : $\varphi_{1E/N}, \varphi_{2E/N}, \varphi_{3E/N}, \varphi_{NE}, \varphi_{12}, \varphi_{23}, \varphi_{31}$	✓*	✓	✓	✓	✓	✓	2x
Direction of rotation (fundamental oscillation) with sign: ROT		✓				✓	2x

We take care of it.

Aggregation interval							
Measurement quantities	½ cycle	10/12 cycles	150/180 cycles	10 min	2 h	4xU 4xI	2x 4xU
Flicker magnitudes of $u_{1E/N}$ , $u_{2E/N}$ , $u_{3E/N}$ , $u_{12}$ , $u_{23}$ , $u_{31}$ : $PxT_{1E/N}$ , $PxT_{2E/N}$ , $PxT_{3E/N}$ , $PxT_{12}$ , $PxT_{23}$ , $PxT_{31}$				✓	✓	✓	2x
Max. flicker detectability of $u_{1E/N}$ , $u_{2E/N}$ , $u_{3E/N}$ , $u_{12}$ , $u_{23}$ , $u_{31}$ : $Pinst_1$ , $Pinst_2$ , $Pinst_3$ , $Pinst_{12}$ , $Pinst_{23}$ , $Pinst_{31}$		✓*		✓		✓	2x
Voltage positive-sequence / negative-sequence / zero-sequence system	✓*	✓	✓	✓	✓	✓	2x
Voltage asymmetry $u_u$		✓	✓	✓	✓	✓	2x
Voltage asymmetry $u_0$		✓	✓	✓	✓	✓	2x
Extrema of $U_{1E/N-1/2}$ , $U_{2E/N-1/2}$ , $U_{3E/N-1/2}$ , $U_{NE-1/2}$ , $U_{12-1/2}$ , $U_{23-1/2}$ , $U_{31-1/2}$				✓		✓	2x
Extrema of $U_{1E/N-10/12}$ , $U_{2E/N-10/12}$ , $U_{3E/N-10/12}$ , $U_{NE-10/12}$ , $U_{12-10/12}$ , $U_{23-10/12}$ , $U_{31-10/12}$				✓		✓	2x
Current positive-sequence / negative-sequence / zero-sequence system		✓	✓	✓	✓	✓	
Current asymmetry $u_u$		✓	✓	✓	✓	✓	
Current asymmetry $u_0$		✓	✓	✓	✓	✓	
Extrema of $I_{1-1/2}$ , $I_{2-1/2}$ , $I_{3-1/2}$ , $I_{E/N-1/2}$				✓		✓	
Extrema of $I_{1-10/12}$ , $I_{2-10/12}$ , $I_{3-10/12}$ , $I_{E/N-10/12}$				✓		✓	
Extrema of $P_{1-10/12}$ , $P_{2-10/12}$ , $P_{3-10/12}$ , $P_{10/12}$				✓		✓	
Extrema of $f_{10s}$ and $f_{10/12}$				✓		✓	✓
Maxima of $U_{S1-10/12}$ , $U_{S2-10/12}$ , $U_{S3-10/12}$ , $U_{SN-10/12}$ , $U_{S12-10/12}$ , $U_{S23-10/12}$ , $U_{S31-10/12}$				✓		✓	2x
Negative deviation [%] of $U_{1E/N}$ , $U_{2E/N}$ , $U_{3E/N}$ , $U_{12}$ , $U_{23}$ , $U_{31}$		✓	✓	✓	✓	✓	2x
Positive deviation [%] of $U_{1E/N}$ , $U_{2E/N}$ , $U_{3E/N}$ , $U_{12}$ , $U_{23}$ , $U_{31}$		✓	✓	✓	✓	✓	2x

## Statistical quantities:

Aggregation interval	Day	Week	Year	4xU 4xI	2x 4xU
<b>Measurement quantities</b>					
Extrema of $U_{1E/N-10/12}$ , $U_{2E/N-10/12}$ , $U_{3E/N-10/12}$ , $U_{NE-10/12}$ , $U_{12-10/12}$ , $U_{23-10/12}$ , $U_{31-10/12}$	✓			✓	2x
Extrema of $U_{1E/N-10min}$ , $U_{2E/N-10min}$ , $U_{3E/N-10min}$ , $U_{NE-10min}$ , $U_{12-10min}$ , $U_{23-10min}$ , $U_{31-10min}$	✓			✓	2x
Maxima of $THD_{1E/N-10min}$ , $THD_{2E/N-10min}$ , $THD_{3E/N-10min}$ , $THD_{12-10min}$ , $THD_{23-10min}$ , $THD_{31-10min}$	✓			✓	2x
Maxima for harmonic subgroups $n = 2nd..40th$ $U_{1E/N-n-10min}$ , $U_{2E/N-n-10min}$ , $U_{3E/N-n-10min}$ , $U_{NE-n-10min}$ , $U_{12-n-10min}$ , $U_{23-n-10min}$ , $U_{31-n-10min}$ across all phases	✓			✓	2x
Maxima for long-term flicker $PLT_{1E/N}$ , $PLT_{2E/N}$ , $PLT_{3E/N}$ , $PLT_{12}$ , $PLT_{23}$ , $PLT_{31}$	✓			✓	2x
Extrema of $f_{10s}$	✓			✓	✓
Extrema of $f_{10/12}$	✓			✓	✓
Extrema of $f_{10min}$	✓			✓	✓
Extrema of $I_{1-10/12}$ , $I_{2-10/12}$ , $I_{3-10/12}$ , $I_{E/N-10/12}$	✓			✓	
Extrema of $I_{1-10/12}$ , $I_{2-10min}$ , $I_{3-10min}$ , $I_{E/N-10min}$	✓			✓	
Extrema of $P_{1-10/12}$ , $P_{2-10/12}$ , $P_{3-10/12}$ , $P_{10/12}$	✓			✓	
Extrema of $P_{1-10/12}$ , $P_{2-10min}$ , $P_{3-10min}$ , $P_{10min}$	✓			✓	
Number auxiliary voltage interruptions	✓	✓	✓	✓	2x
Number of evaluation intervals	✓	✓	✓	✓	2x
Number of frequency deviations, narrow tolerance	✓	✓	✓	✓	2x
Number of frequency deviations, wide tolerance	✓	✓	✓	✓	2x
Number of intermittent overvoltages at the network frequency	✓	✓	✓	✓	2x
Number of fast voltage changes	✓	✓	✓	✓	2x
Number of voltage dips	✓	✓	✓	✓	2x
Number of short voltage interruptions	✓	✓	✓	✓	2x
Number of long voltage interruptions	✓	✓	✓	✓	2x
Number of 10-minute intervals	✓	✓	✓	✓	2x
Number of slow voltage deviations	✓	✓	✓	✓	2x
Number of times harmonic distortions exceeded	✓	✓	✓	✓	2x
Number of times voltage asymmetry exceeded	✓	✓	✓	✓	2x
Number of 2-hour intervals	✓	✓	✓	✓	2x
Number of times PLT exceeded	✓	✓	✓	✓	2x
Number of times signal voltage exceeded	✓	✓	✓	✓	2x
Number of weeks during which the frequency too frequently exceeds the narrow tolerance range			✓	✓	2x
Number of weeks during which slow voltage changes too frequently exceed the range			✓	✓	2x

We take care of it.

Aggregation interval	Day	Week	Year	4xU 4xI	2x 4xU
<b>Measurement quantities</b>					
Number of weeks during which harmonic distortions too frequently exceed the range			✓	✓	2x
Number of weeks during which voltage asymmetry too frequently exceeded the range			✓	✓	2x
Number of weeks during which flicker PLT too frequently exceeds the range			✓	✓	2x
Number of days on which signal voltage is too frequently exceeded			✓	✓	2x
Time sum for auxiliary voltage interruptions	✓	✓	✓	✓	2x
Time sum for measurement time	✓	✓	✓	✓	2x
Time sum for frequency deviations, narrow tolerance	✓	✓	✓	✓	2x
Time sum for frequency deviations, wide tolerance	✓	✓	✓	✓	2x
Time sum for intermittent overvoltage at the network frequency	✓	✓	✓	✓	2x
Time sum for fast voltage changes	✓	✓	✓	✓	2x
Time sum for voltage dips	✓	✓	✓	✓	2x
Time sum for short voltage interruptions	✓	✓	✓	✓	2x
Time sum for long voltage interruptions	✓	✓	✓	✓	2x
Time sum for exceeded signal voltages	✓	✓	✓	✓	2x

## Overview of events:

Symbol	Designation	Event value
RST	System reset, start event	Error code
RSTx	System reset, stop event	Error code
STATERR	Station error flags	Error flags
SYNC	Frequency valid	f
NOTSYNC	Frequency invalid	0
TIMESSET	Time setting	Time difference [s]
NEWDAY	New day initialised	Day index
BININPUT	Status change at binary inputs	Last status Current status
COM1ERR	Error COM1	Error code
TRG_RX	External trigger, receive	0
COM2ERR	Error COM2	Error code
DFN	Frequency deviation (narrow tolerance), start event	10-second trigger value
DFNx	Frequency deviation (narrow tolerance), stop event	10-second extreme value
DFW	Frequency deviation (wide tolerance), start event	10-second trigger value
DFWx	Frequency deviation (wide tolerance), stop event	10-second extreme value
TRG_TX	Ext. trigger, send	Bit ID
TRG_W0	Status change in trigger word#0	Status word



Symbol	Designation	Event value
TRG_W1	Status change in trigger word#1	Status word
TRG_W2	Status change in trigger word#2	Status word
TEDUR	Duration of transient event [s]	Event duration [s]
RUN_REC	Status change in recording of data classes	Status word
BINOUTPUT	Status change at binary outputs	Last status Current status
TIMESYNC	Status change, external time synchronisation	Status word
EVNTOF	DSP event buffer overflow	Level
RSTEVAL_1	Reset event evaluation, line 1	0
EVAL_1	Event evaluation, start event, line 1	0
EVALx_1	Event evaluation, stop event, line 1	0
RECA_1	New recording in recorder A1	"Absolute index"
RECS_1	New recording in recorder S1	"Absolute index"
RECB_1	New recording in recorder B1	"Absolute index"
TRANSNOSTIC	Status message Transnestic	Status word
TEDUR	Duration of transient event [s]	Event duration [s]
RECC_1	New recording in recorder C1	"Absolute index"
OV1E_1	Overvoltage U1E, start event, line 1	10-ms trigger value
OV1Ex_1	Overvoltage U1E, stop event, line 1	10-ms maximum value
OV2E_1	Overvoltage U2E, start event, line 1	10-ms trigger value
OV2Ex_1	Overvoltage U2E, stop event, line 1	10-ms maximum value
OV3E_1	Overvoltage U3E, start event, line 1	10-ms trigger value
OV3Ex_1	Overvoltage U3E, stop event, line 1	10-ms maximum value
OVNE_1	Overvoltage UNE, start event, line 1	10-ms trigger value
OVNEx_1	Overvoltage UNE, stop event, line 1	10-ms maximum value
VS1E_1	Swell U1E, start event, line 1	10-ms trigger value
VS1Ex_1	Swell U1E, stop event, line 1	10-ms maximum value
VS2E_1	Swell U2E, start event, line 1	10-ms trigger value
VS2Ex_1	Swell U2E, stop event, line 1	10-ms maximum value
VS3E_1	Swell U3E, start event, line 1	10-ms trigger value
VS3Ex_1	Swell U3E, stop event, line 1	10-ms maximum value
VS12_1	Swell U12, start event, line 1	10-ms trigger value
VS12x_1	Swell U12, stop event, line 1	10-ms maximum value
VS23_1	Swell U23, start event, line 1	10-ms trigger value
VS23x_1	Swell U23, stop event, line 1	10-ms maximum value
VS31_1	Swell U31, start event, line 1	10-ms trigger value
VS31x_1	Swell U31, stop event, line 1	10-ms maximum value
VD1E_1	Dip U1E, start event, line 1	10-ms trigger value
VD1Ex_1	Dip U1E, stop event, line 1	10-ms minimum value
VD2E_1	Dip U2E, start event, line 1	10-ms trigger value
VD2Ex_1	Dip U2E, stop event, line 1	10-ms minimum value
VD3E_1	Dip U3E, start event, line 1	10-ms trigger value

Symbol	Designation	Event value
VD3Ex_1	Dip U3E, stop event, line 1	10-ms minimum value
VD12_1	Dip U12, start event, line 1	10-ms trigger value
VD12x_1	Dip U12, stop event, line 1	10-ms minimum value
VD23_1	Dip U23, start event, line 1	10-ms trigger value
VD23x_1	Dip U23, stop event, line 1	10-ms minimum value
VD31_1	Dip U31, start event, line 1	10-ms trigger value
VD31x_1	Dip U31, stop event, line 1	10-ms minimum value
DD1E_1	Voltage dip U1E, start event, line 1	10-ms trigger value
DD1Ex_1	Voltage dip U1E, stop event, line 1	10-ms minimum value
DD2E_1	Voltage dip U2E, start event, line 1	10-ms trigger value
DD2Ex_1	Voltage dip U2E, stop event, line 1	10-ms minimum value
DD3E_1	Voltage dip U3E, start event, line 1	10-ms trigger value
DD3Ex_1	Voltage dip U3E, stop event, line 1	10-ms minimum value
DD12_1	Voltage dip U12, start event, line 1	10-ms trigger value
DD12x_1	Voltage dip U12, stop event, line 1	10-ms minimum value
DD23_1	Voltage dip U23, start event, line 1	10-ms trigger value
DD23x_1	Voltage dip U23, stop event, line 1	10-ms minimum value
DD31_1	Voltage dip U31, start event, line 1	10-ms trigger value
DD31x_1	Voltage dip U31, stop event, line 1	10-ms minimum value
SI1E_1	Interruption to supply U1E, start event, line 1	10-ms trigger value
SI1Ex_1	Interruption to supply U1E, stop event, line 1	10-ms minimum value
SI2E_1	Interruption to supply U2E, start event, line 1	10-ms trigger value
SI2Ex_1	Interruption to supply U2E, stop event, line 1	10-ms minimum value
SI3E_1	Interruption to supply U3E, start event, line 1	10-ms trigger value
SI3Ex_1	Interruption to supply U3E, stop event, line 1	10-ms minimum value
SI12_1	Interruption to supply U12, start event, line 1	10-ms trigger value
SI12x_1	Interruption to supply U12, stop event, line 1	10-ms minimum value
SI23_1	Interruption to supply U23, start event, line 1	10-ms trigger value
SI23x_1	Interruption to supply U23, stop event, line 1	10-ms minimum value
SI31_1	Interruption to supply U31, start event, line 1	10-ms trigger value
SI31x_1	Interruption to supply U31, stop event, line 1	10-ms minimum value
SVC1E_1	Slow voltage deviation U1E, line 1	10-minute average value
SVC2E_1	Slow voltage deviation U2E, line 1	10-minute average value
SVC3E_1	Slow voltage deviation U3E, line 1	10-minute average value
SVC12_1	Slow voltage deviation U12, line 1	10-minute average value
SVC23_1	Slow voltage deviation U23, line 1	10-minute average value
SVC31_1	Slow voltage deviation U31, line 1	10-minute average value
PLT1E_1	Long-term flicker U1E exceeded, line 1	2-hour average value
PLT2E_1	Long-term flicker U2E exceeded, line 1	2-hour average value
PLT3E_1	Long-term flicker U3E exceeded, line 1	2-hour average value
PLT12_1	Long-term flicker U12 exceeded, line 1	2-hour average value

Symbol	Designation	Event value
PLT23_1	Long-term flicker U23 exceeded, line 1	2-hour average value
PLT31_1	Long-term flicker U31 exceeded, line 1	2-hour average value
NUU_1	Voltage asymmetry exceeded, line 1	10-minute average value
THD1EV_1	THD of U1E exceeded, line 1	10-minute average value
THD2EV_1	THD of U2E exceeded, line 1	10-minute average value
THD3EV_1	THD of U3E exceeded, line 1	10-minute average value
THD12V_1	THD of U12 exceeded, line 1	10-minute average value
THD23V_1	THD of U23 exceeded, line 1	10-minute average value
THD31V_1	THD of U31 exceeded, line 1	10-minute average value
HN1EV_1	Harmonic U1E exceeded, line 1	Order of harmonic
HN2EV_1	Harmonic U2E exceeded, line 1	Order of harmonic
HN3EV_1	Harmonic U3E exceeded, line 1	Order of harmonic
HN12V_1	Harmonic U12 exceeded, line 1	Order of harmonic
HN23V_1	Harmonic U23 exceeded, line 1	Order of harmonic
HN31V_1	Harmonic U31 exceeded, line 1	Order of harmonic
PST1E_1	Short-term flicker U1E exceeded, line 1	10-minute average value
PST2E_1	Short-term flicker U2E exceeded, line 1	10-minute average value
PST3E_1	Short-term flicker U3E exceeded, line 1	10-minute average value
PST12_1	Short-term flicker U12 exceeded, line 1	10-minute average value
PST23_1	Short-term flicker U23 exceeded, line 1	10-minute average value
PST31_1	Short-term flicker U31 exceeded, line 1	10-minute average value
PI1	Interval active power L1	Interval average value
PI2	Interval active power L2	Interval average value
PI3	Interval active power L3	Interval average value
PI	Interval active power of the network	Interval average value
RSTEVAL_2	Reset event evaluation, line 2	0
EVAL_2	Event evaluation, start event, line 2	0
EVALx_2	Event evaluation, stop event, line 2	0
RECA_2	New recording in recorder A2	"Absolute index"
RECS_2	New recording in recorder S2	"Absolute index"
RECB_2	New recording in recorder B2	"Absolute index"
RECC_2	New recording in recorder C2	"Absolute index"
OV1E_2	Overvoltage U1E, start event, line 2	10-ms trigger value
OV1Ex_2	Overvoltage U1E, stop event, line 2	10-ms maximum value
OV2E_2	Overvoltage U2E, start event, line 2	10-ms trigger value
OV2Ex_2	Overvoltage U2E, stop event, line 2	10-ms maximum value
OV3E_2	Overvoltage U3E, start event, line 2	10-ms trigger value
OV3Ex_2	Overvoltage U3E, stop event, line 2	10-ms maximum value
OVNE_2	Overvoltage UNE, start event, line 2	10-ms trigger value
OVNEx_2	Overvoltage UNE, stop event, line 2	10-ms maximum value
VS1E_2	Swell U1E, start event, line 2	10-ms trigger value

Symbol	Designation	Event value
VS1Ex_2	Swell U1E, stop event, line 2	10-ms maximum value
VS2E_2	Swell U2E, start event, line 2	10-ms trigger value
VS2Ex_2	Swell U2E, stop event, line 2	10-ms maximum value
VS3E_2	Swell U3E, start event, line 2	10-ms trigger value
VS3Ex_2	Swell U3E, stop event, line 2	10-ms maximum value
VS12_2	Swell U12, start event, line 2	10-ms trigger value
VS12x_2	Swell U12 stop event, line 2	10-ms maximum value
VS23_2	Swell U23, start event, line 2	10-ms trigger value
VS23x_2	Swell U23, stop event, line 2	10-ms maximum value
VS31_2	Swell U31, start event, line 2	10-ms trigger value
VS31x_2	Swell U31, stop event, line 2	10-ms maximum value
VD1E_2	Dip U1E, start event, line 2	10-ms trigger value
VD1Ex_2	Dip U1E, stop event, line 2	10-ms minimum value
VD2E_2	Dip U2E, start event, line 2	10-ms trigger value
VD2Ex_2	Dip U2E, stop event, line 2	10-ms minimum value
VD3E_2	Dip U3E, start event, line 2	10-ms trigger value
VD3Ex_2	Dip U3E, stop event, line 2	10-ms minimum value
VD12_2	Dip U12, start event, line 2	10-ms trigger value
VD12x_2	Dip U12, stop event, line 2	10-ms minimum value
VD23_2	Dip U23, start event, line 2	10-ms trigger value
VD23x_2	Dip U23, stop event, line 2	10-ms minimum value
VD31_2	Dip U31, start event, line 2	10-ms trigger value
VD31x_2	Dip U31, stop event, line 2	10-ms minimum value
DD1E_2	Voltage dip U1E, start event, line 2	10-ms trigger value
DD1Ex_2	Voltage dip U1E, stop event, line 2	10-ms minimum value
DD2E_2	Voltage dip U2E, start event, line 2	10-ms trigger value
DD2Ex_2	Voltage dip U2E, stop event, line 2	10-ms minimum value
DD3E_2	Voltage dip U3E, start event, line 2	10-ms trigger value
DD3Ex_2	Voltage dip U3E, stop event, line 2	10-ms minimum value
DD12_2	Voltage dip U12, start event, line 2	10-ms trigger value
DD12x_2	Voltage dip U12, stop event, line 2	10-ms minimum value
DD23_2	Voltage dip U23, start event, line 2	10-ms trigger value
DD23x_2	Voltage dip U23, stop event, line 2	10-ms minimum value
DD31_2	Voltage dip U31, start event, line 2	10-ms trigger value
DD31x_2	Voltage dip U31, stop event, line 2	10-ms minimum value
SI1E_2	Interruption to supply U1E, start event, line 2	10-ms trigger value
SI1Ex_2	Interruption to supply U1E, stop event, line 2	10-ms minimum value
SI2E_2	Interruption to supply U2E, start event, line 2	10-ms trigger value
SI2Ex_2	Interruption to supply U2E, stop event, line 2	10-ms minimum value
SI3E_2	Interruption to supply U3E, start event, line 2	10-ms trigger value
SI3Ex_2	Interruption to supply U3E, stop event, line 2	10-ms minimum value

Symbol	Designation	Event value
SI12_2	Interruption to supply U12, start event, line 2	10-ms trigger value
SI12x_2	Interruption to supply U12, stop event, line 2	10-ms minimum value
SI23_2	Interruption to supply U23, start event, line 2	10-ms trigger value
SI23x_2	Interruption to supply U23, stop event, line 2	10-ms minimum value
SI31_2	Interruption to supply U31, start event, line 2	10-ms trigger value
SI31x_2	Interruption to supply U31, stop event, line 2	10-ms minimum value
SVC1E_2	Slow voltage deviation U1E, line 2	10-minute average value
SVC2E_2	Slow voltage deviation U2E, line 2	10-minute average value
SVC3E_2	Slow voltage deviation U3E, line 2	10-minute average value
SVC12_2	Slow voltage deviation U12, line 2	10-minute average value
SVC23_2	Slow voltage deviation U23, line 2	10-minute average value
SVC31_2	Slow voltage deviation U31, line 2	10-minute average value
PLT1E_2	Long-term flicker U1E exceeded, line 2	2-hour average value
PLT2E_2	Long-term flicker U2E exceeded, line 2	2-hour average value
PLT3E_2	Long-term flicker U3E exceeded, line 2	2-hour average value
PLT12_2	Long-term flicker U12 exceeded, line 2	2-hour average value
PLT23_2	Long-term flicker U23 exceeded, line 2	2-hour average value
PLT31_2	Long-term flicker U31 exceeded, line 2	2-hour average value
NUU_2	Voltage asymmetry exceeded, line 2	10-minute average value
THD1E_2	THD of U1E exceeded, line 2	10-minute average value
THD2E_2	THD of U2E exceeded, line 2	10-minute average value
THD3E_2	THD of U3E exceeded, line 2	10-minute average value
THD12_2	THD of U12 exceeded, line 2	10-minute average value
THD23_2	THD of U23 exceeded, line 2	10-minute average value
THD31_2	THD of U31 exceeded, line 2	10-minute average value
HN1E_2	Harmonic U1E exceeded, line 2	Order of harmonic
HN2E_2	Harmonic U2E exceeded, line 2	Order of harmonic
HN3E_2	Harmonic U3E exceeded, line 2	Order of harmonic
HN12_2	Harmonic U12 exceeded, line 2	Order of harmonic
HN23_2	Harmonic U23 exceeded, line 2	Order of harmonic
HN31_2	Harmonic U31 exceeded, line 2	Order of harmonic
PST1E_2	Short-term flicker U1E exceeded, line 2	10-minute average value
PST2E_2	Short-term flicker U2E exceeded, line 2	10-minute average value
PST3E_2	Short-term flicker U3E exceeded, line 2	10-minute average value
PST12_2	Short-term flicker U12 exceeded, line 2	10-minute average value
PST23_2	Short-term flicker U23 exceeded, line 2	10-minute average value
PST31_2	Short-term flicker U31 exceeded, line 2	10-minute average value
US1_2	US1-3s exceeded, start event, line 2	Trigger value
US1x_2	US1-3s exceeded, stop event, line 2	Maximum value
US2_2	US2-3s exceeded, start event, line 2	Trigger value
US2x_2	US2-3s exceeded, stop event, line 2	Maximum value

Symbol	Designation	Event value
US3_2	US3-3s exceeded, start event, line 2	Trigger value
US3x_2	US3-3s exceeded, stop event, line 2	Maximum value
US12_2	US12-3s exceeded, start event, line 2	Trigger value
US12x_2	US12-3s exceeded, stop event, line 2	Maximum value
US23_2	US23-3s exceeded, start event, line 2	Trigger value
US23x_2	US23-3s exceeded, stop event, line 2	Maximum value
US31_2	US31-3s exceeded, start event, line 2	Trigger value
US31x_2	US31-3s exceeded, stop event, line 2	Maximum value
US1_1	US1-3s exceeded, start event, line 1	Trigger value
US1x_1	US1-3s exceeded, stop event, line 1	Maximum value
US2_1	US2-3s exceeded, start event, line 1	Trigger value
US2x_1	US2-3s exceeded, stop event, line 1	Maximum value
US3_1	US3-3s exceeded, start event, line 1	Trigger value
US3x_1	US3-3s exceeded, stop event, line 1	Maximum value
US12_1	US12-3s exceeded, start event, line 1	Trigger value
US12x_1	US12-3s exceeded, stop event, line 1	Maximum value
US23_1	US23-3s exceeded, start event, line 1	Trigger value
US23x_1	US23-3s exceeded, stop event, line 1	Maximum value
US31_1	US31-3s exceeded, start event, line 1	Trigger value
US31x_1	US31-3s exceeded, stop event, line 1	Maximum value
FVC1_1	Voltage change U1E/U1N, start event, line 1	Trigger value
FVC1x_1	Voltage change U1E/U1N, stop event, line 1	Maximum value
FVC2_1	Voltage change U2E/U2N, start event, line 1	Trigger value
FVC2x_1	Voltage change U2E/U2N, stop event, line 1	Maximum value
FVC3_1	Voltage change U3E/U3N, start event, line 1	Trigger value
FVC3x_1	Voltage change U3E/U3N, stop event, line 1	Maximum value
FVC12_1	Voltage change U12, start event, line 1	Trigger value
FVC12x_1	Voltage change U12, stop event, line 1	Maximum value
FVC23_1	Voltage change U23, start event, line 1	Trigger value
FVC23x_1	Voltage change U23, stop event, line 1	Maximum value
FVC31_1	Voltage change U31, start event, line 1	Trigger value
FVC31x_1	Voltage change U31, stop event, line 1	Maximum value
FVC1_2	Voltage change U1E/U1N, start event, line 2	Trigger value
FVC1x_2	Voltage change U1E/U1N, stop event, line 2	Maximum value
FVC2_2	Voltage change U2E/U2N, start event, line 2	Trigger value
FVC2x_2	Voltage change U2E/U2N, stop event, line 2	Maximum value
FVC3_2	Voltage change U3E/U3N, start event, line 2	Trigger value
FVC3x_2	Voltage change U3E/U3N, stop event, line 2	Maximum value
FVC12_2	Voltage change U12, start event, line 2	Trigger value
FVC12x_2	Voltage change U12, stop event, line 2	Maximum value
FVC23_2	Voltage change U23, start event, line 2	Trigger value

Symbol	Designation	Event value
FVC23x_2	Voltage change U23, stop event, line 2	Maximum value
FVC31_2	Voltage change U31, start event, line 2	Trigger value
FVC31x_2	Voltage change U31, stop event, line 2	Maximum value
F10S	Network frequency	10-second frequency value

## Overview of binary message signals, 4xU and 4xl

ID	Symbol	Description
0	NoSignal	No signal
1	Rst	Auxiliary voltage interruption
2	IntErr	Internal error
3	ComErr	COM error
4	LanErr	LAN error
5	WDT1	Communication watchdog 1 : Timeout
6	FsyncErr	Frequency synchronisation error (V2 and V3 only!)
7	ClipErr	Measurement range exceeded
8	MSRs2	New 10/12-period values
9	MSR3s	New 150/180-period values
10	MSR10min	New 10-min values
11	MSR2h	New 2-hour values
12	MSRDay	New daily values
13	MSRRecA	New fault record in recorder A1
14	MSRRecB	New fault record in recorder B1
15	MSRRecC	New fault record in recorder C
16	MSREvnt	New event
17	MEMs2	Maximum level of 0.2-second buffer exceeded
18	MEM3s	Maximum level of 3-second buffer exceeded
19	MEM10min	Maximum level of 10-minute buffer exceeded
20	MEM2h	Maximum level of 2-hour buffer exceeded
21	MEMDay	Maximum level of day buffer exceeded
22	MEMRecA	Maximum level of recorder A exceeded
23	MEMRecB	Maximum level of recorder B exceeded
24	MEMRecC	Maximum level of recorder C exceeded
25	MEMEvnt	Maximum level of event buffer 1 exceeded
26	Nfc	Frequency deviation, narrow tolerance
27	Wfc	Frequency deviation, wide tolerance
28	Tov	Intermittent overvoltage at the network frequency
29	Fvc	Fast voltage change
30	Fvd	Voltage dip
31	Si	Short voltage interruption

ID	Symbol	Description
32	Li	Long voltage interruption
33	SVC	Slow voltage deviation (10 minutes)
34	HD	Harmonic distortions exceeded (10 minutes)
35	UU	Voltage asymmetry exceeded (10 minutes)
36	PST	PST exceeded (10 minutes)
37	PLT	PLT exceeded (2 hours)
38	DINNfc_w	Narrow frequency range too frequently exceeded [week]
39	DINNfc_y	Narrow frequency range too frequently exceeded [year]
40	DINTov_y	Maximum number of intermittent overvoltages at the network frequency exceeded [year]
41	DINFvc_d	Maximum number of fast voltage changes exceeded [day]
42	DINFvc_y	Maximum number of fast voltage changes exceeded [year]
43	DINFvd_y	Maximum number of voltage dips exceeded [year]
44	DINSi_y	Maximum number of short supply interruptions exceeded [year]
45	DINLi_y	Maximum number of long supply interruptions exceeded [year]
46	DINSVC_w	Slow voltage change range exceeded too frequently. [week]
47	DINHd_w	Harmonic distortion range exceeded too frequently [week]
48	DINUU_w	Asymmetrical voltage range exceeded too frequently [week]
49	DINPLT_w	Flicker range exceeded too frequently [week]
50	DINSig_d	Signal voltage exceeded too frequently [day]
51	DINSig_w	Signal voltage exceeded too frequently [week]
52	DINSig_y	Maximum number of days exceeded on which the signal voltage is exceeded too frequently [year]
53	Sig	Signal voltage exceeded
54	MSRRecS	New fault record in recorder S
55	MEMRecS	Maximum level of recorder S exceeded
56	TIMESYNC	Status of external time synchronisation
57	TIMESSET	Time setting
58	WDT2	Communication watchdog 2 : Timeout
59	TN_K1P	TRANSNOSTIC : Phase-earth short-circuit in own network (behind measurement point)
60	TN_K2P	TRANSNOSTIC : Phase-phase short-circuit in own network (behind measurement point)
61	TN_K3P	TRANSNOSTIC : 3-phase short-circuit in own network (behind measurement point)
62	TN_KIM	TRANSNOSTIC : Short-circuit before measurement point
63	TN_PEX	TRANSNOSTIC : Peak in own network (behind measurement point)
64	TN_PIM	TRANSNOSTIC : Peak before measurement point
65	BIN_1	Binary input 1
66	BIN_2	Binary input 2
67	BIN_3	Binary input 3
68	BIN_4	Binary input 4



ID	Symbol	Description
69	BIN_5	Binary input 5
70	BIN_6	Binary input 6
71	BIN_7	Binary input 7
72	BIN_8	Binary input 8
73	BIN_9	Binary input 9
74	BIN_10	Binary input 10
75	BIN_11	Binary input 11
76	BIN_12	Binary input 12
77	BIN_13	Binary input 13
78	BIN_14	Binary input 14
79	BIN_15	Binary input 15
80	BIN_16	Binary input 16
81	Eval	Enable event evaluation
82	ENs2	Enable recording of 10/12-period values
83	EN3s	Enable recording of 150/180-period values
84	EN10min	Enable recording of 10-minute values
85	EN2h	Enable recording of 2-hour values
86	ENDay	Enable recording of daily values
87	ENRecA	Enable recording of fault records in recorder A
88	ENRecB	Enable recording of fault records in recorder B
89	ENRecC	Enable recording of fault records in recorder C
90	ENRecS	Enable recording of fault records in recorder S
91	ENEvnt	Enable event recording
92	TrgTx	External trigger signal sent
93	TrgRx	External trigger signal received
94	TrgLTF	Trigger signal: Lower limit for half-period frequency
95	TrgUTF	Trigger signal: Upper limit for half-period frequency
96	TrgSTF	Trigger signal: Half-period frequency jump
97	TrgSW	Trigger signal: Software triggers
98	TrgL1	Trigger signal: Lower limit for half-period voltage U1
99	TrgL2	Trigger signal: Lower limit for half-period voltage U2
100	TrgL3	Trigger signal: Lower limit for half-period voltage U3
101	TrgL12	Trigger signal: Lower limit for half-period voltage U12
102	TrgL23	Trigger signal: Lower limit for half-period voltage U23
103	TrgL31	Trigger signal: Lower limit for half-period voltage U31
104	TrgU1	Trigger signal: Upper limit for half-period voltage U1
105	TrgU2	Trigger signal: Upper limit for half-period voltage U2
106	TrgU3	Trigger signal: Upper limit for half-period voltage U3
107	TrgU12	Trigger signal: Upper limit for half-period voltage U12
108	TrgU23	Trigger signal: Upper limit for half-period voltage U23
109	TrgU31	Trigger signal: Upper limit for half-period voltage U31

ID	Symbol	Description
110	TrgUTN	Trigger signal: Upper limit for half-period voltage UNE
111	TrgST1	Trigger signal: Half-period voltage jump U1
112	TrgST2	Trigger signal: Half-period voltage jump U2
113	TrgST3	Trigger signal: Half-period voltage jump U3
114	TrgST12	Trigger signal: Half-period voltage jump U12
115	TrgST23	Trigger signal: Half-period voltage jump U23
116	TrgST31	Trigger signal: Half-period voltage jump U31
117	TrgSTN	Trigger signal: Half-period voltage jump UNE
118	TrgSTP1	Trigger signal: Half-period voltage phase jump U1
119	TrgSTP2	Trigger signal: Half-period voltage phase jump U2
120	TrgSTP3	Trigger signal: Half-period voltage phase jump U3
121	TrgET1	Trigger signal: Envelope curve U1
122	TrgET2	Trigger signal: Envelope curve U2
123	TrgET3	Trigger signal: Envelope curve U3
124	TrgET12	Trigger signal: Envelope curve U12
125	TrgET23	Trigger signal: Envelope curve U23
126	TrgET31	Trigger signal: Envelope curve U31
127	TrgETN	Trigger signal: Envelope curve UNE
128	TrgLPS	Trigger signal: Lower limit for half-period voltage in a positive-sequence system
129	TrgUPS	Trigger signal: Upper limit for half-period voltage in a positive-sequence system
130	TrgUNS	Trigger signal: Upper limit for half-period voltage in a negative-sequence system
131	TrgUZS	Trigger signal: Upper limit for half-period voltage in a zero-sequence system
132	TrgLT1_I	Trigger signal: Lower limit for half-period current I1
133	TrgLT2_I	Trigger signal: Lower limit for half-period current I2
134	TrgLT3_I	Trigger signal: Lower limit for half-period current I3
135	TrgUT1_I	Trigger signal: Upper limit for half-period current I1
136	TrgUT2_I	Trigger signal: Upper limit for half-period current I2
137	TrgUT3_I	Trigger signal: Upper limit for half-period current I3
138	TrgUTN_I	Trigger signal: Upper limit for half-period current IN
139	TrgST1_I	Trigger signal: Half-period current jump I1
140	TrgST2_I	Trigger signal: Half-period current jump I2
141	TrgST3_I	Trigger signal: Half-period current jump I3
142	TrgSTN_I	Trigger signal: Half-period current jump IN

Device 8 x U

ID	Symbol	Description
0	NoSignal	No signal
1	Rst	Auxiliary voltage interruption
2	IntErr	Internal error
3	ComErr	COM error
4	LanErr	LAN error
5	WDT1	Communication watchdog 1 : Timeout
6	FsyncErr	Frequency synchronisation error
7	ClipErr_1	Measurement range exceeded, line 1
8	MSRs2_1	New 10/12-period values, line 1
9	MSR3s_1	New 150/180-period values, line 1
10	MSR10min_1	New 10-min values, line 1
11	MSR2h_1	New 2-hour values, line 1
12	MSRDay_1	New daily values, line 1
13	MSRRecA_1	New fault record in recorder A, line 1
14	MSRRecB_1	New fault record in recorder B, line 1
15	MSRRecC_1	New fault record in recorder C, line 1
16	MSREvnt_1	New event, line 1
17	MEMs2_1	Maximum level of 0.2-second buffer exceeded, line 1
18	MEM3s_1	Maximum level of 3-second buffer exceeded, line 1
19	MEM10min_1	Maximum level of 10-minute buffer exceeded, line 1
20	MEM2h_1	Maximum level of 2-hour buffer exceeded, line 1
21	MEMDay_1	Maximum level of day buffer exceeded, line 1
22	MEMRecA_1	Maximum level of recorder A exceeded, line 1
23	MEMRecB_1	Maximum level of recorder B exceeded, line 1
24	MEMRecC_1	Maximum level of recorder C exceeded, line 1
25	MEMEvnt_1	Maximum level of event buffer exceeded, line 1
26	Nfc_1	Frequency change, narrow tolerance, line 1
27	Wfc_1	Frequency change, wide tolerance, line 1
28	Tov_1	Intermittent overvoltage at the network frequency, line 1
29	Fvc_1	Fast voltage change, line 1
30	Fvd_1	Voltage dip, line 1
31	Si_1	Short voltage interruption, line 1
32	Li_1	Long voltage interruption, line 1
33	SVC_1	Slow voltage deviation (10 minutes), line 1
34	HD_1	Harmonic distortions exceeded (10 minutes), line 1
35	UU_1	Voltage asymmetry exceeded (10 minutes), line 1
36	PST_1	PST exceeded (10 minutes), line 1
37	PLT_1	PLT exceeded (2 hours), line 1
38	DINNfc_w_1	Narrow frequency range too frequently exceeded [week], line 1
39	DINNfc_y_1	Narrow frequency range too frequently exceeded [year], line 1
40	DINTov_y_1	Maximum number of intermittent overvoltages at the network frequency exceeded [year], line 1

ID	Symbol	Description
41	DINFvc_d_1	Maximum number of fast voltage changes exceeded [day], line 1
42	DINFvc_y_1	Maximum number of fast voltage changes exceeded [year], line 1
43	DINFvd_y_1	Maximum number of voltage dips exceeded [year], line 1
44	DINSi_y_1	Maximum number of short interruptions to the supply exceeded [year], line 1
45	DINLi_y_1	Maximum number of long interruptions to the supply exceeded [year], line 1
46	DINSVC_w_1	Slow voltage change range exceeded too frequently [week], line 1
47	DINHd_w_1	Harmonic distortion range exceeded too frequently [week], line 1
48	DINUU_w_1	Asymmetrical voltage range exceeded too frequently [week], line 1
49	DINPLT_w_1	Flicker range exceeded too frequently [week], line 1
50	ClipErr_2	Measurement range exceeded, line 2
51	MSRs2_2	New 10/12-period values, line 2
52	MSR3s_2	New 150/180-period values, line 2
53	MSR10min_2	New 10-min values, line 2
54	MSR2h_2	New 2-hour values, line 2
55	MSRDay_2	New daily values, line 2
56	MSRRecA_2	New fault record in recorder A, line 2
57	MSRRecB_2	New fault record in recorder B, line 2
58	MSRRecC_2	New fault record in recorder C, line 2
59	MSREvnt_2	New event, line 2
60	MEMs2_2	Maximum level of 0.2-second buffer exceeded, line 2
61	MEM3s_2	Maximum level of 3-second buffer exceeded, line 2
62	MEM10min_2	Maximum level of 10-minute buffer exceeded, line 2
63	MEM2h_2	Maximum level of 2-hour buffer exceeded, line 2
64	MEMDay_2	Maximum level of day buffer exceeded, line 2
65	MEMRecA_2	Maximum level of recorder A exceeded, line 2
66	MEMRecB_2	Maximum level of recorder B exceeded, line 2
67	MEMRecC_2	Maximum level of recorder C exceeded, line 2
68	MEMEvnt_2	Maximum level of event buffer exceeded
69	Nfc_2	Frequency change, narrow tolerance, line 2
70	Wfc_2	Frequency change, wide tolerance, line 2
71	Tov_2	Intermittent overvoltage at the network frequency, line 2
72	Fvc_2	Fast voltage change, line 2
73	Fvd_2	Voltage dip, line 2
74	Si_2	Short voltage interruption, line 2
75	Li_2	Long voltage interruption, line 2
76	SVC_2	Slow voltage deviation (10 minutes), line 2
77	HD_2	Harmonic distortions exceeded (10 minutes), line 2
78	UU_2	Voltage asymmetry exceeded (10 minutes), line 2
79	PST_2	PST exceeded (10 minutes), line 2
80	PLT_2	PLT exceeded (2 hours), line 2

ID	Symbol	Description
81	DINNfc_w_2	Narrow frequency range too frequently exceeded [week], line 2
82	DINNfc_y_2	Narrow frequency range too frequently exceeded [year], line 2
83	DINTov_y_2	Maximum number of intermittent overvoltages at the network frequency exceeded [year], line 2
84	DINFvc_d_2	Maximum number of fast voltage changes exceeded [day], line 2
85	DINFvc_y_2	Maximum number of fast voltage changes exceeded [year], line 2
86	DINFvd_y_2	Maximum number of voltage dips exceeded [year], line 2
87	DINSi_y_2	Maximum number of short interruptions to the supply exceeded [year], line 2
88	DINLi_y_2	Maximum number of long interruptions to the supply exceeded [year], line 2
89	DINSVC_w_2	Slow voltage change range exceeded too frequently [week], line 2
90	DINHd_w_2	Harmonic distortion range exceeded too frequently [week], line 2
91	DINUU_w_2	Asymmetrical voltage range exceeded too frequently [week], line 2
92	DINPLT_w_2	Flicker range exceeded too frequently [week], line 2
93	DINSig_d_2	Signal voltage exceeded too frequently [day], line 2
94	DINSig_w_2	Signal voltage exceeded too frequently [week], line 2
95	DINSig_y_2	Maximum number of days exceeded on which the signal voltage is exceeded too frequently [year], line 2
96	Sig_2	Signal voltage exceeded, line 2
97	MSRRecS_2	New fault record in recorder S, line 2
98	MEMRecS_2	Maximum level of recorder S exceeded, line 2
99	DINSig_d_1	Signal voltage exceeded too frequently [day], line 1
100	DINSig_w_1	Signal voltage exceeded too frequently [week], line 1
101	DINSig_y_1	Maximum number of days exceeded on which the signal voltage is exceeded too frequently [year], line 1
102	Sig_1	Signal voltage exceeded, line 1
103	MSRRecS_1	New fault record in recorder S, line 1
104	MEMRecS_1	Maximum level of recorder S exceeded, line 1
105	Eval_1	Status of event evaluation, line 1
106	ENs2_1	Status of recording for 10/12-period values, line 1
107	EN3s_1	Status of recording for 150/180-period values, line 1
108	EN10min_1	Status of recording for 10-min values, line 1
109	EN2h_1	Status of recording for 2-hour values, line 1
110	ENDay_1	Status of recording for daily values, line 1
111	ENRecA_1	Status of recording for fault record in recorder A, line 1
112	ENRecB_1	Status of recording for fault record in recorder B, line 1
113	ENRecC_1	Status of recording for fault record in recorder C, line 1
114	ENRecS_1	Status of recording for fault record in recorder S, line 1
115	ENEvt_1	Status of recording for event, line 1
116	Eval_2	Status of event evaluation, line 2
117	ENs2_2	Status of recording for 10/12-period values, line 2
118	EN3s_2	Status of recording for 150/180-period values, line 2
119	EN10min_2	Status of recording for 10-min values, line 2

ID	Symbol	Description
120	EN2h_2	Status of recording for 2-hour values, line 2
121	ENDay_2	Status of recording for daily values, line 2
122	ENRecA_2	Status of recording for fault record in recorder A, line 2
123	ENRecB_2	Status of recording for fault record in recorder B, line 2
124	ENRecC_2	Status of recording for fault record in recorder C, line 2
125	ENRecS_2	Status of recording for fault record in recorder S, line 2
126	ENEvt_2	Status of recording for event, line 2
127	TIMESYNC	Status of external time synchronisation: 0 = not synchronised, 1 = synchronised
128	TIMESET	Time setting
129	BIN_1	Binary input 1
130	BIN_2	Binary input 2
131	BIN_3	Binary input 3
132	BIN_4	Binary input 4
133	BIN_5	Binary input 5
134	BIN_6	Binary input 6
135	BIN_7	Binary input 7
136	BIN_8	Binary input 8
137	BIN_9	Binary input 9
138	BIN_10	Binary input 10
139	BIN_11	Binary input 11
140	BIN_12	Binary input 12
141	BIN_13	Binary input 13
142	BIN_14	Binary input 14
143	BIN_15	Binary input 15
144	BIN_16	Binary input 16
145	WDT2	Communication watchdog 2 : Timeout
146	TrgTx	External trigger signal sent
147	TrgRx	External trigger signal received
148	TrgLTF	Trigger signal: Lower limit for half-period frequency
149	TrgUTF	Trigger signal: Upper limit for half-period frequency
150	TrgSTF	Trigger signal: Half-period frequency jump
151	TrgSW_1	Trigger signal: Software trigger, line 1
152	TrgL1_1	Trigger signal: Lower limit for half-period voltage U1, line 1
153	TrgL2_1	Trigger signal: Lower limit for half-period voltage U2, line 1
154	TrgL3_1	Trigger signal: Lower limit for half-period voltage U3, line 1
155	TrgL12_1	Trigger signal: Lower limit for half-period voltage U12, line 1
156	TrgL23_1	Trigger signal: Lower limit for half-period voltage U23, line 1
157	TrgL31_1	Trigger signal: Lower limit for half-period voltage U3, line 1
158	TrgU1_1	Trigger signal: Upper limit for half-period voltage U1, line 1
159	TrgU2_1	Trigger signal: Upper limit for half-period voltage U2, line 1
160	TrgU3_1	Trigger signal: Upper limit for half-period voltage U3, line 1

ID	Symbol	Description
161	TrgUT12_1	Trigger signal: Upper limit for half-period voltage U12, line 1
162	TrgUT23_1	Trigger signal: Upper limit for half-period voltage U23, line 1
163	TrgUT31_1	Trigger signal: Upper limit for half-period voltage U3, line 1
164	TrgUTN_1	Trigger signal: Upper limit for half-period voltage UNE, line 1
165	TrgST1_1	Trigger signal: Half-period voltage jump U1, line 1
166	TrgST2_1	Trigger signal: Half-period voltage jump U2, line 1
167	TrgST3_1	Trigger signal: Half-period voltage jump U3, line 1
168	TrgST12_1	Trigger signal: Half-period voltage jump U12, line 1
169	TrgST23_1	Trigger signal: Half-period voltage jump U23, line 1
170	TrgST31_1	Trigger signal: Half-period voltage jump U31, line 1
171	TrgSTN_1	Trigger signal: Half-period voltage jump UNE, line 1
172	TrgSTP1_1	Trigger signal: Half-period voltage phase jump U1, line 1
173	TrgSTP2_1	Trigger signal: Half-period voltage phase jump U2, line 1
174	TrgSTP3_1	Trigger signal: Half-period voltage phase jump U3, line 1
175	TrgET1_1	Trigger signal: Envelope curve U1, line 1
176	TrgET2_1	Trigger signal: Envelope curve U2, line 1
177	TrgET3_1	Trigger signal: Envelope curve U3, line 1
178	TrgET12_1	Trigger signal: Envelope curve U12, line 1
179	TrgET23_1	Trigger signal: Envelope curve U23, line 1
180	TrgET31_1	Trigger signal: Envelope curve U31, line 1
181	TrgETN_1	Trigger signal: Envelope curve UNE, line 1
182	TrgLPS_1	Trigger signal: Lower limit for half-period voltage in a positive-sequence system, line 1
183	TrgUPS_1	Trigger signal: Upper limit for half-period voltage in a positive-sequence system, line 1
184	TrgUNS_1	Trigger signal: Upper limit for half-period voltage in a negative-sequence system, line 1
185	TrgUZS_1	Trigger signal: Upper limit for half-period voltage in a zero-sequence system, line 1
186	TrgSW_2	Trigger signal: Software trigger, line 2
187	TrgL1_2	Trigger signal: Lower limit for half-period voltage U1, line 2
188	TrgL2_2	Trigger signal: Lower limit for half-period voltage U2, line 2
189	TrgL3_2	Trigger signal: Lower limit for half-period voltage U3, line 2
190	TrgL12_2	Trigger signal: Lower limit for half-period voltage U12, line 2
191	TrgL23_2	Trigger signal: Lower limit for half-period voltage U23, line 2
192	TrgL31_2	Trigger signal: Lower limit for half-period voltage U3, line 2
193	TrgUT1_2	Trigger signal: Upper limit for half-period voltage U1, line 2
194	TrgUT2_2	Trigger signal: Upper limit for half-period voltage U2, line 2
195	TrgUT3_2	Trigger signal: Upper limit for half-period voltage U3, line 2
196	TrgUT12_2	Trigger signal: Upper limit for half-period voltage U12, line 2
197	TrgUT23_2	Trigger signal: Upper limit for half-period voltage U23, line 2
198	TrgUT31_2	Trigger signal: Upper limit for half-period voltage U3, line 2

ID	Symbol	Description
199	TrgUTN_2	Trigger signal: Upper limit for half-period voltage UNE, line 2
200	TrgST1_2	Trigger signal: Half-period voltage jump U1, line 2
201	TrgST2_2	Trigger signal: Half-period voltage jump U2, line 2
202	TrgST3_2	Trigger signal: Half-period voltage jump U3, line 2
203	TrgST12_2	Trigger signal: Half-period voltage jump U12, line 2
204	TrgST23_2	Trigger signal: Half-period voltage jump U23, line 2
205	TrgST31_2	Trigger signal: Half-period voltage jump U31, line 2
206	TrgSTN_2	Trigger signal: Half-period voltage jump UNE, line 2
207	TrgSTP1_2	Trigger signal: Half-period voltage phase jump U1, line 2
208	TrgSTP2_2	Trigger signal: Half-period voltage phase jump U2, line 2
209	TrgSTP3_2	Trigger signal: Half-period voltage phase jump U3, line 2
210	TrgET1_2	Trigger signal: Envelope curve U1, line 2
211	TrgET2_2	Trigger signal: Envelope curve U2, line 2
212	TrgET3_2	Trigger signal: Envelope curve U3, line 2
213	TrgET12_2	Trigger signal: Envelope curve U12, line 2
214	TrgET23_2	Trigger signal: Envelope curve U23, line 2
215	TrgET31_2	Trigger signal: Envelope curve U31, line 2
216	TrgETN_2	Trigger signal: Envelope curve UNE, line 2
217	TrgLPS_2	Trigger signal: Lower limit for half-period voltage in a positive-sequence system, line 2
218	TrgUPS_2	Trigger signal: Upper limit for half-period voltage in a positive-sequence system, line 2
219	TrgUNS_2	Trigger signal: Upper limit for half-period voltage in a negative-sequence system, line 2
220	TrgUZS_2	Trigger signal: Upper limit for half-period voltage in a zero-sequence system, line 2



## Reference conditions

Reference temperature	$23^{\circ}\text{C} \pm 1 \text{ K}$
Input parameters	$U = U_n \pm 10\%$ $I = I_n \pm 10\%$
Auxiliary voltage	$H = H_n \pm 1 \%$
Frequency	$= f_{\text{nom}} \pm 1\%$
Other	IEC 60688 - Part 1

## Measurement data acquisition

Sampling rate	10240 Hz
ADC resolution	24-bit
Anti-aliasing filter	Analogue filter: 3rd order Butterworth filter Digital filter : sinc5 decimation filter (ADC)
Nominal frequency	$f_{\text{nom}} = 50 \text{ Hz}, 60 \text{ Hz}$
Frequency measurement range	$f_{\text{nom}} \pm 15\%$

## Data memory

Calibration parameter, hardware identification	Serial EEPROM, 256x16 bit
Firmware	FLASH (CPU), 4 MB
Non-volatile measurement data (4 MB), settings	NV RAM (CPU), 4 MB, battery backup (Li battery)
Volatile measurement data (64 MB, background memory)	SDRAM (DSP), 64 MB

## Electromagnetic compatibility

### CE conformity

**Interference immunity** EN 61326  
EN 61000-6-2

**Emitted interference** EN 61326  
EN 61000-6-4

### ESD

IEC 61000-4-2 8 kV / 16 kV  
IEC 60 255-22-2

### Electromagnetic fields

IEC 61000-4-3 10 V/m  
IEC 60 255-22-3

### Burst

IEC 61000-4-4 4 kV / 2 kV  
IEC 60 255-22-4

### Surge 1 MHz burst

IEC 61000-4-5 4 kV / 2 kV  
IEC 61000-4-12 2.5 kV, Class III  
IEC 60 255-22-1

### Conducted high frequency magnetic fields

IEC 61000-4-6 10 V, 150 kHz ... 80 MHz  
IEC 61000-4-8 100 A/m continuous  
All layers 1000 A/m 1 s

### Voltage dips

IEC 61000-4-11 30% 0.02s, 60% 1 s

### Emitted interference

EN 61326  
EN 61000-6-4

**Housing** 30...230 MHz, 40 dB  
at a distance of 10 m 230...1000 MHz, 47 dB

**AC power supply connection** 0.15...0.5 MHz, 79 dB  
0.5...5 MHz, 73 dB  
at a distance of 10 m 5...30 MHz, 73 dB

## Electrical safety

Degree of protection	1
Degree of pollution	2
Measurement category	CAT III / 300 V

## Operating voltages

50 V	230 V
E-LAN, COM server COM1 ... COM2 time/trigger	Auxiliary voltage Binary inputs Relay outputs

## Power supply

Feature	H1	H2
AC nominal range	100V ... 240V	-
AC operating range	90 ... 264 V	
DC nominal range	100 ... 300 V	20 ... 70 V
DC operating range	100 ... 300 V	18 ... 72 V
Power consumption	≤ 15 VA	≤ 15 Watts
Frequency	50 ... 60 Hz	-
Microfuse	T1 250V / 1A	T2 250 V / 2A

The following applies for all features:

Voltage interruptions of ≤ 80 ms do not cause a fault or loss of data.

## Binary inputs and outputs, analogue outputs

Feature	BO	BI	AO	AI	Status / life contact
M00	5	16	-	-	1
M92	3	6	4	-	1
M93	6	-	-	-	1
M94	-	-	8	-	-
M95	2	-	6	-	1
M96	5	16	-	-	1
M97	-	16	-	4	1
M98	-	16	-	4	1

*Table 2*

BO: Relay outputs

BI: Binary inputs

AO: Analogue outputs

AI: Analogue inputs

## Environmental conditions

### Temperature range

Function	-15 ... +50°C
Transport and storage	-25 ... +65°C

### Humidity

No condensation on 30 days/year	95 % rel.
------------------------------------	-----------

### Dry, cold

IEC 60068-2-1	-15°C / 16 h
---------------	--------------

### Dry, hot

IEC 60068-2-2	+55°C / 16 h
---------------	--------------

### Constant humid heat

IEC 60068-2-3	+ 40 °C / 93 % / 2 days
---------------	-------------------------

### Cyclical humid heat

IEC 60068-2-30	12+12h, 6 cycles, +55°C/93%
----------------	-----------------------------

### Toppling

IEC 60068-2-31	100 mm drop, unwrapped
----------------	------------------------

### Vibration

IEC 60255-21-1	Class 1
----------------	---------

### Impact

IEC 60255-21-2	Class 1
----------------	---------

## Mechanical design

---

### Plug-in module

Front panel	Aluminium, RAL 7035 grey
Height	3 HE (132.5 mm)
Width	18 TE (91.44 mm)
Circuit board	160 mm x 100 mm
Weight	≤ 1.0 kg
Module – degree of protection	IP 00
Socket connector - degree of protection	IP 00
Mounting	conforms to DIN 41494 Part 5
Plug-in connectors	DIN 41612

### Housing

The PQI-D is also very flexible with regard to the type of housing used. Some possible types of housing are described below. The standard versions are the two described at feature B90 and feature B92. Since the number of inputs, outputs, COMs, etc. in a 19" plug-in module is much greater than the number of available terminals on the housing, pin assignment must be individually specified for versions B90...B92.

Material	Plastic
Degree of protection	Housing IP 65
Weight	≤ 1.5 kg
Dimensions	See figures 5 and 6
Connection elements	Screw terminals

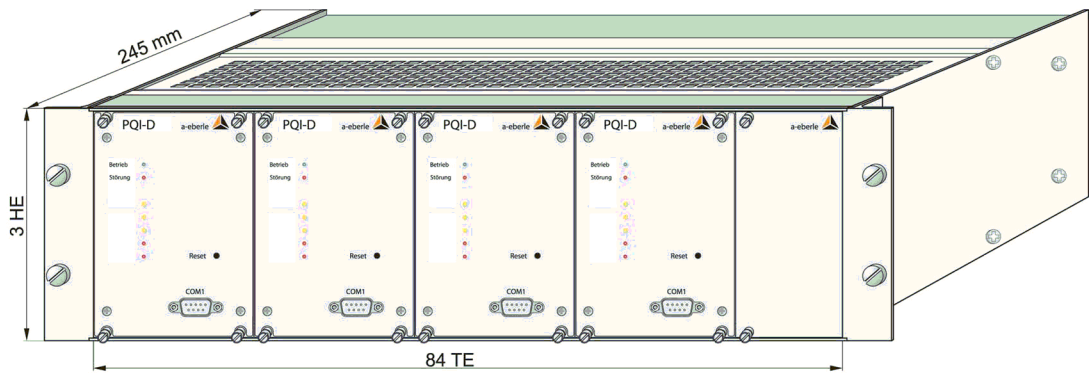

19" plug-in modules in mounting rack 84 TE feature B92

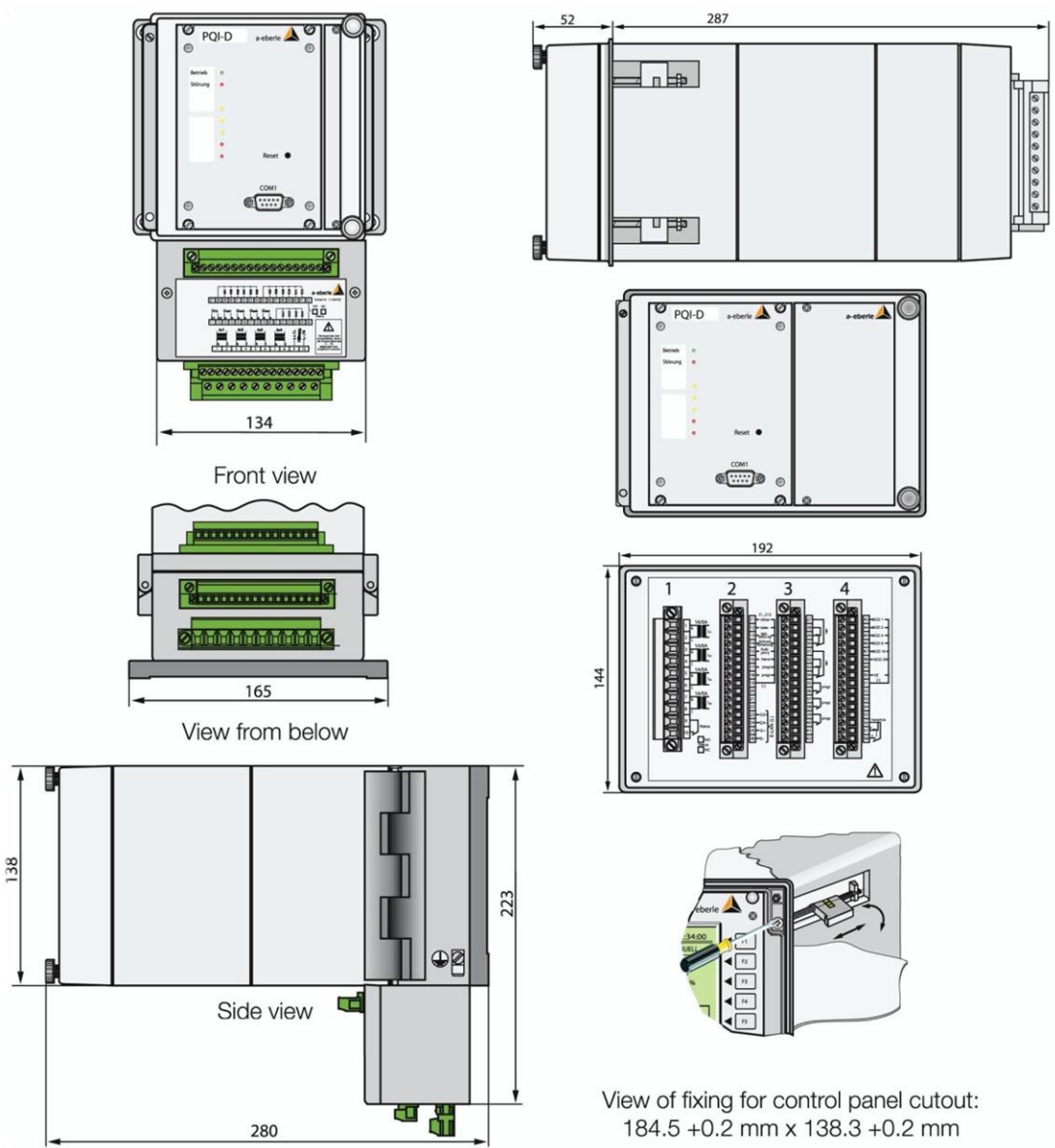

Wall mounting housing 20 TE, feature B90

Panel mounting housing 30 TE, feature B91

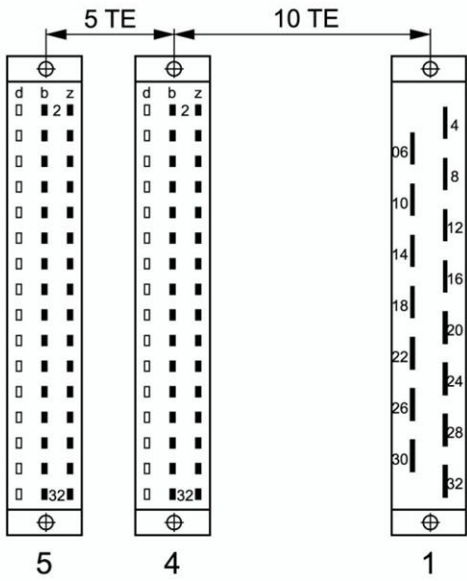

Position of socket connectors for feature C00

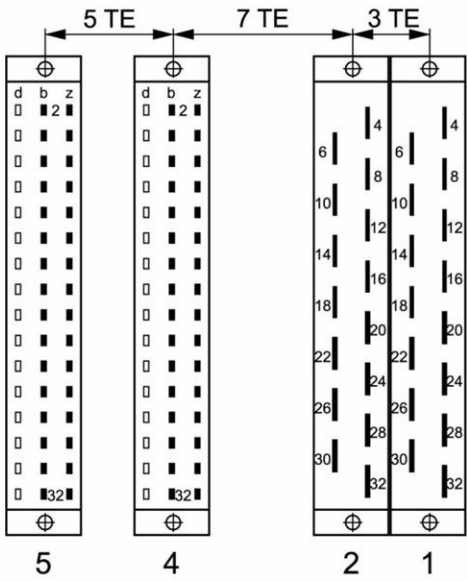

Position of socket connectors for feature C10

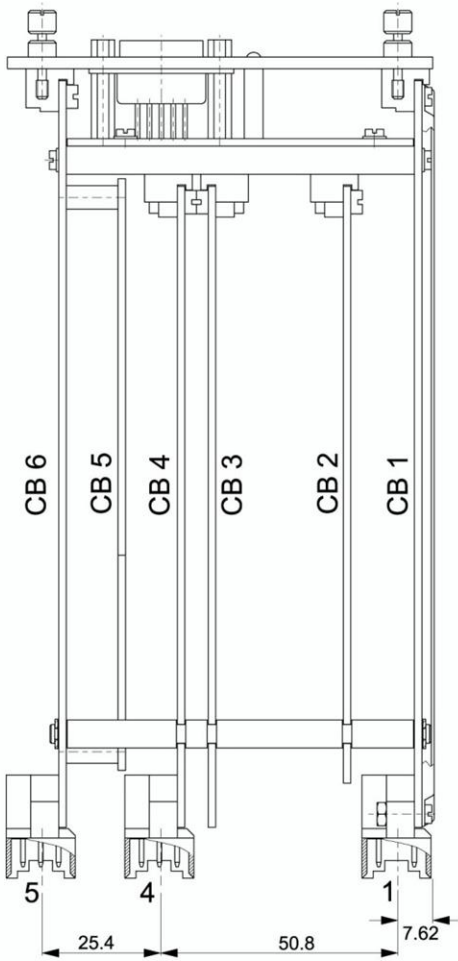

Position of blade connectors and PCBs for feature C00

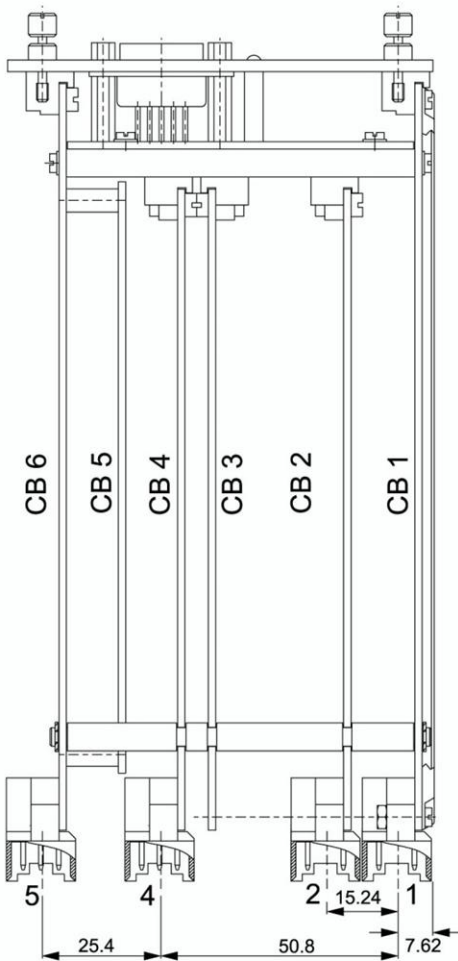

Position of blade connectors and PCBs for feature C10



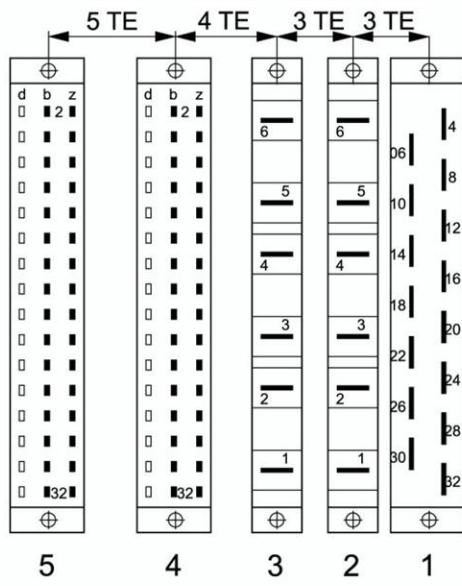

Position of the socket connectors for feature C20... C31

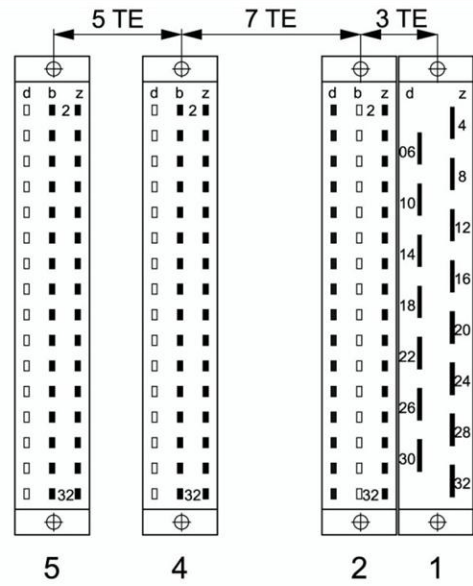

Position of the socket connectors for feature C40... C41

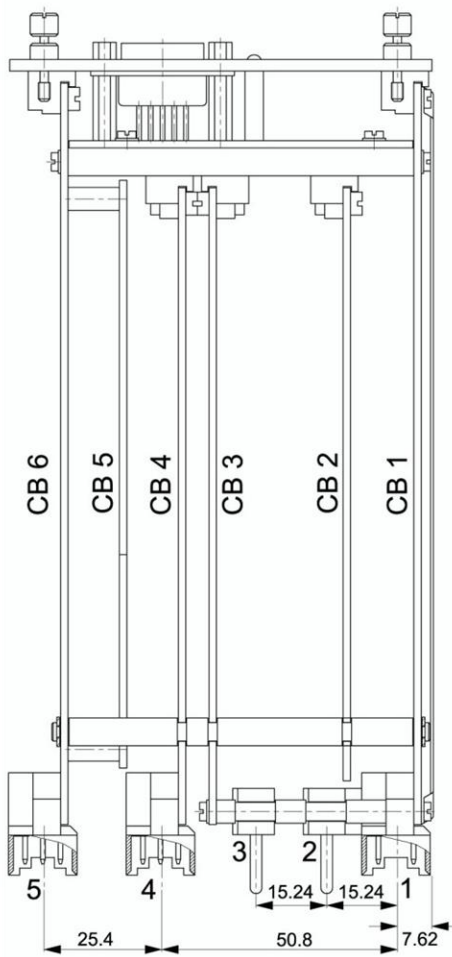

Position of the blade connectors and PCBs for feature C20...C31

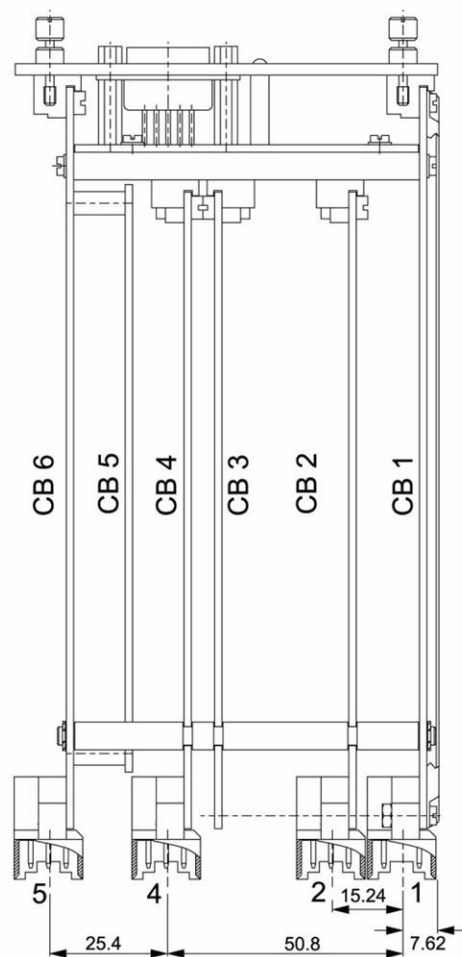

Position of the blade connectors and PCBs for feature C40...C41

## Assignment of socket connectors 1 ... 5



**Note:** Please refer to pages 7 and 8 for the position of the socket connectors.

### Socket connector 1

Obligatory for all feature combinations from C00 ... C31

Auxiliary voltage, voltage inputs

Input voltages  $U_{1E}...U_{3E}$ ,  $U_{NE}$ ,  $U_{sync}$  and auxiliary voltage

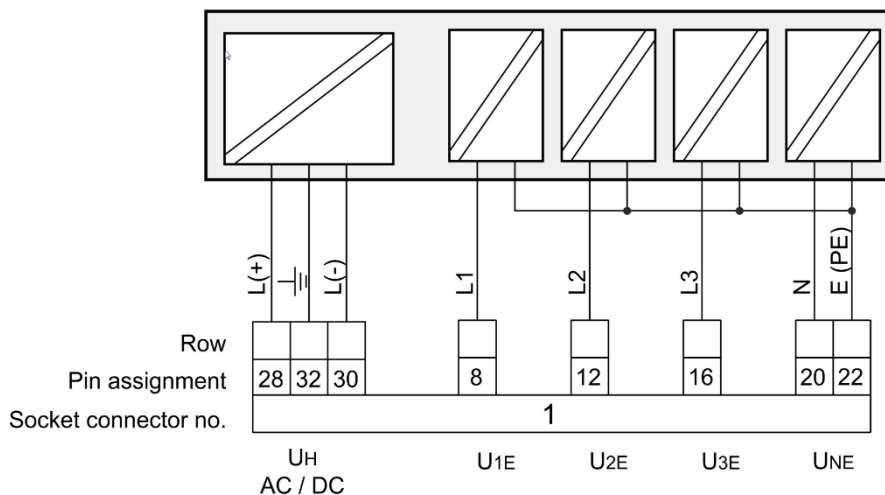

Designation	Function	Pin	Assignment
Phase voltage L1 (AC)	$U_{1E}$	L1	8
		E	22
Phase voltage L2 (AC)	$U_{2E}$	L2	12
		E	22
Phase voltage L3 (AC)	$U_{3E}$	L3	16
		E	22
Neutral earth voltage	$U_{NE}$	N	20
		E (PE)	22
Auxiliary voltage	$U_H$	L (+)	28
		L (-)	30
Auxiliary voltage	$U_H$	PE	32

Voltage inputs  $U_{1E} ... U_{3E}$  can be used for a rated value of up to 110 V (E1) or 230 V (E2).

### Socket connector 2

Socket connector 2 - not required for feature C00

Socket connector 2 - feature C10

**4 voltage inputs**



**Note:** Voltages for busbar 2 are indicated by '´

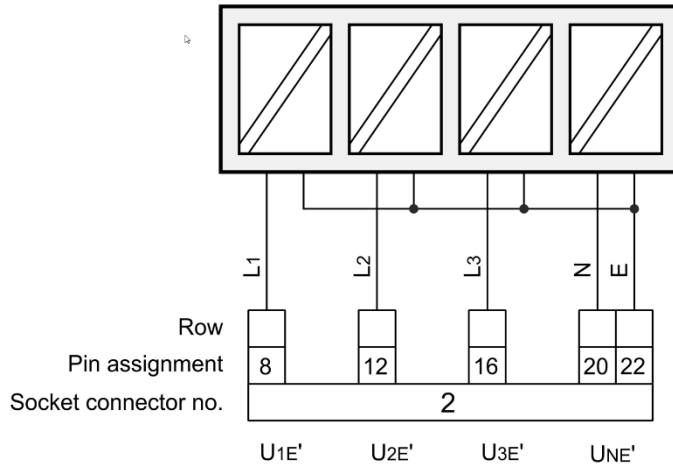

Designation		Function	Pin	Assignment
Phase voltage L1 (AC)	U <sub>1E</sub>	L1	8	
		E	22	
Phase voltage L2 (AC)	U <sub>2E</sub>	L2	12	
		E	22	
Phase voltage L3 (AC)	U <sub>3E</sub>	L3	16	
		E	22	
Neutral earth voltage	U <sub>NE</sub>	N	20	
		E (PE)	22	

**Socket connector 2 - features C40 and C41**

**4 current inputs for current clamps**



Note: The mV inputs are not galvanically isolated from each other or from the CPU

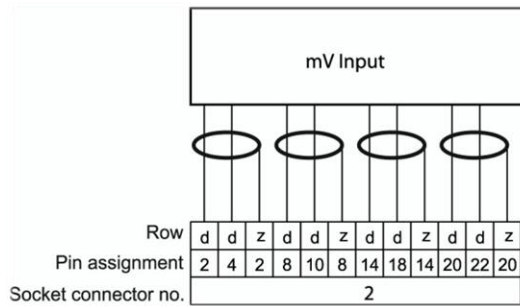

Designation		Function	Pin	Assignment
Phase current I1 (AC)	I <sub>1</sub>	+	d2	
		-	d4	
		Shielding	z2	
Phase current I2 (AC)	I <sub>2</sub>	+	d8	
		-	d10	
		Shielding	z8	
Phase current I3 (AC)	I <sub>3</sub>	+	d14	
		-	d16	
		Shielding	z14	
Sum current (AC)	I <sub>0</sub>	+	d20	
		-	d22	
		Shielding	z20	

Socket connector 2 - feature C20 ... C31

**Current inputs via high-current contact with upstream short-circuit contact**

Designation		Function	Pin	Assignment
Phase current I1 (AC)	I <sub>1</sub>	S1	6	
		S2	5	
Phase current I2 (AC)	I <sub>2</sub>	S1	4	
		S2	3	
Phase current I3 (AC)	I <sub>3</sub>	S1	2	
		S2	1	

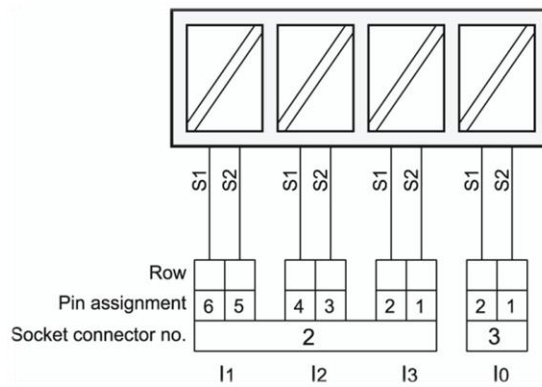

## Socket connector 3 - feature C20 ... C31

### Current inputs

- Version with: 4 voltage inputs and
- 4 current inputs via high-current contacts

Designation		Function	Pin	Assignment
Not assigned	-	-	6	
		-	5	
Not assigned	-	-	4	
		-	3	
Sum current (AC)	I <sub>0</sub>	S1	2	
		S2	1	

## Socket connector 4

### Socket connector 4 - feature M00 / M96

### Binary inputs, outputs

- Version with: 16 binary inputs
- 5 binary outputs (NO contacts)
- 1 status relay

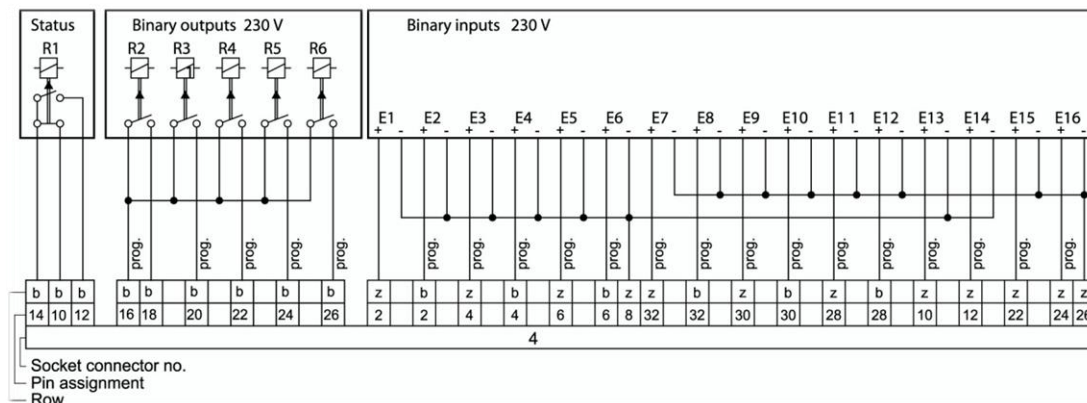

Designation		Function	Pin	Assignment
Status	Relay R1	NC contact NO contact Pole	b10 b12 b14	Freely programmable
Binary outputs 230 V	R2	NO contact	b18	Freely programmable
	R3	NO contact	b20	Freely programmable
	R4	NO contact	b22	Freely programmable
	R5	NO contact	b24	Freely programmable
	R6	NO contact	b26	Freely programmable
	R2...R6	Pole	b16	
Binary inputs 230 V	E1	+	z2	Freely programmable
	E2	+	b2	Freely programmable
	E3	+	z4	Freely programmable
	E4	+	b4	Freely programmable
	E5	+	z6	Freely programmable
	E6	+	b6	Freely programmable
	E1...E6 E13, E14	GND	z8	
	E7	+	z32	Freely programmable
	E8	+	b32	Freely programmable
	E9	+	z30	Freely programmable
	E10	+	b30	Freely programmable
	E11	+	z28	Freely programmable
	E12	+	b28	Freely programmable
	E13	+	z10	Freely programmable
	E14	+	z12	Freely programmable
	E15	+	z22	Freely programmable
E16	+	z24	Freely programmable	
E7...E12 E15, E16	GND	z26		

Socket connector 4 - feature M92

**Binary inputs, outputs, analogue outputs**

- Version with: 6 binary inputs
- 2 binary outputs (NO contacts)
- 4 analogue outputs
- 1 status relay

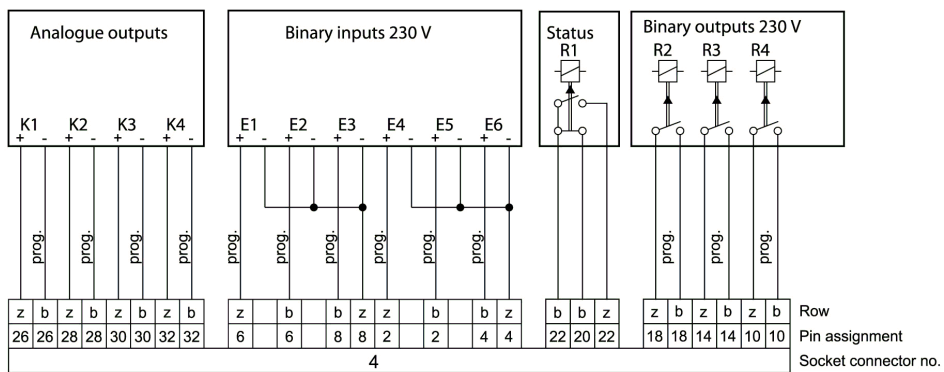

Designation	Function	Pin	Assignment	
Analogue outputs	K1	+ -	z26 b26	Freely programmable
	K2	+ -	z28 b28	Freely programmable
	K3	+ -	z30 b30	Freely programmable
	K4	+ -	z32 b32	Freely programmable
Binary inputs 230 V	E1	+	z6	Freely programmable
	E2	+	b6	Freely programmable
	E3	+	b8	Freely programmable
	E1...E3	GND	z8	
	E4	+	z2	Freely programmable
	E5	+	b2	Freely programmable
	E6	+	b4	Freely programmable
E4...E6	GND	z4		



Binary outputs 230 V	Status R1	NC contact NO contact Pole	z20 z22 b22	
Binary outputs 230 V	R2	NO contact Pole	b18 z18	Freely programmable
	R3	NO contact Pole	b14 z14	Freely programmable
	R4	NO contact Pole	b10 z10	Freely programmable

### Socket connector 4 - feature M93

#### Binary outputs

Version with:     6     binary outputs  
                   1     status relay

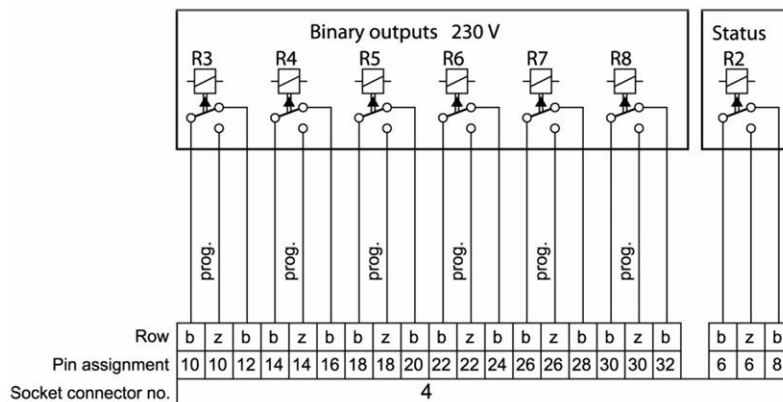

Designation	Function	Pin	Assignment	
Binary outputs 230 V (Relays 1 to 6)	R3	Pole NC contact NO contact	b10 b12 z10	Freely programmable
	R4	Pole NC contact NO contact	b14 b16 z14	Freely programmable
	R5	Pole NC contact NO contact	b18 b20 z18	Freely programmable
	R6	Pole NC contact NO contact	b22 b24 z22	Freely programmable
	R7	Pole NC contact NO contact	b26 b28 z26	Freely programmable

We take care of it.

	R8	Pole NC contact NO contact	b30 b32 z30	Freely programmable
Binary outputs 230 V	Status R2	Pole NC contact NO contact	b6 b8 z6	

### Socket connector 4 - feature M94

#### Analogue outputs

Version with: 8 analogue outputs

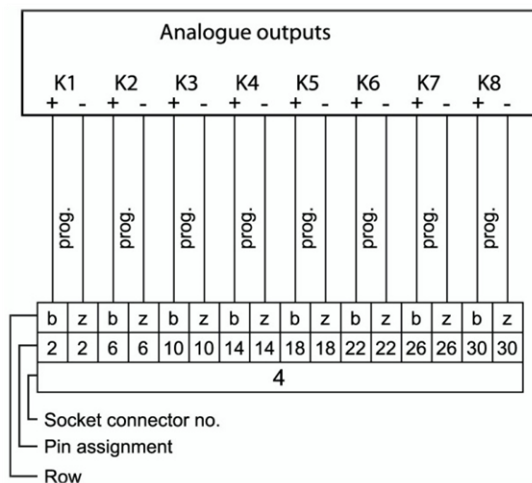

Designation	Function	Pin	Assignment	
Analogue outputs	K1	mA outputs + -	b2 z2	Freely programmable
	K2	mA outputs + -	b6 z6	Freely programmable
	K3	mA outputs + -	b10 z10	Freely programmable
	K4	mA outputs + -	b14 z14	Freely programmable
	K5	mA outputs + -	b18 z18	Freely programmable
	K6	mA outputs + -	b22 z22	Freely programmable
	K7	mA outputs + -	b26 z26	Freely programmable
	K8	mA outputs + -	b30 z30	Freely programmable

## Socket connector 4 - feature M95

### Analogue outputs, binary outputs

Version with:     6     analogue outputs  
                   2     binary outputs (NO contacts)  
                   1     status relay

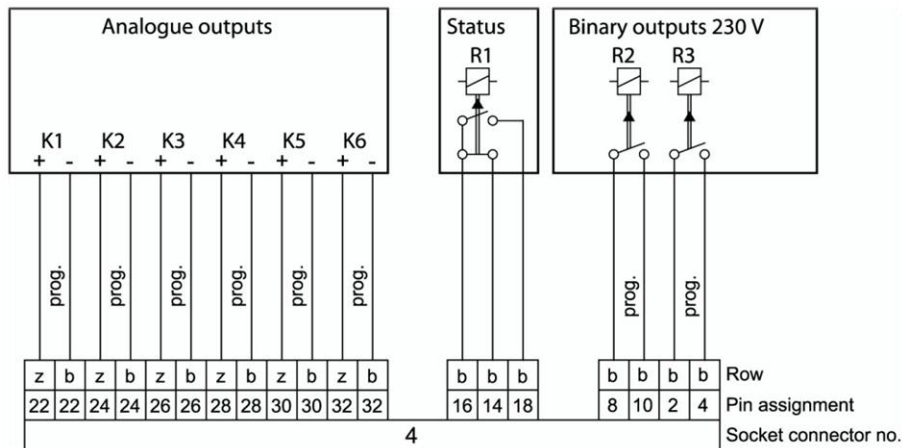

Designation	Function	Pin	Assignment	
Analogue outputs	K1	+ -	z22 b22	Freely programmable
	K2	+ -	z24 b24	Freely programmable
	K3	+ -	z26 b26	Freely programmable
	K4	+ -	z28 b28	Freely programmable
	K5	+ -	z30 b30	Freely programmable
	K6	+ -	z32 b32	Freely programmable
Binary outputs 230 V	Status R1	NC contact NO contact Pole	b14 b18 b16	
	R2	NO contact Pole	b10 b8	Freely programmable
Binary outputs 230 V	R3	NO contact Pole	B4 b2	Freely programmable

Socket connector 4 - feature M97 / M98

**Binary inputs, analogue inputs**

- Version with: 16 Binary inputs
- 4 Analogue inputs
- 1 status relay

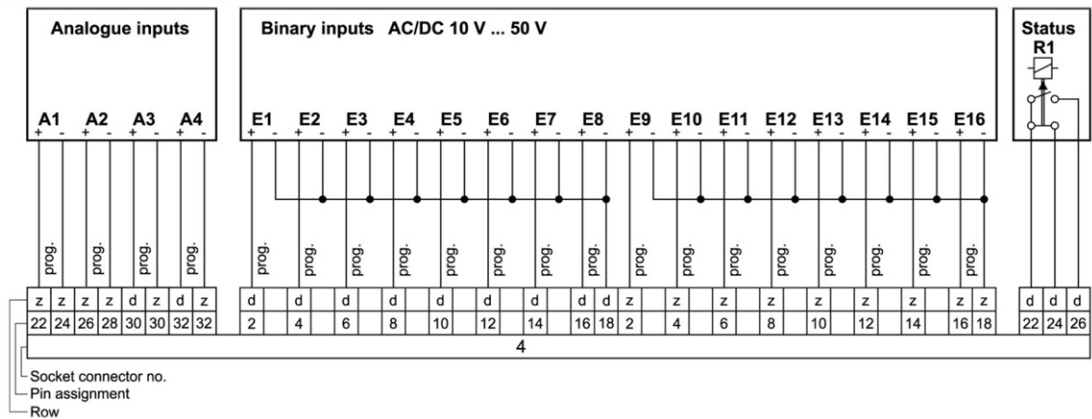

Designation		Function	Pin	Assignment
Analogue inputs	A1	+ -	z22 z24	Freely programmable
	A2	+ -	z26 z28	Freely programmable
	A3	+ -	d30 z30	Freely programmable
	A4	+ -	d32 z32	Freely programmable
Binary inputs 230 V	E1	+	d2	Freely programmable
	E2	+	d4	Freely programmable
	E3	+	d6	Freely programmable
	E4	+	d8	Freely programmable
	E5	+	d10	Freely programmable
	E6	+	d12	Freely programmable
	E7	+	d14	Freely programmable
	E8	+	d16	Freely programmable
	E1...E8	GND	d18	
	E9	+	z2	Freely programmable
E10	+	z4	Freely programmable	

	E11	+	z6	Freely programmable
	E12	+	z8	Freely programmable
	E13	+	z10	Freely programmable
	E14	+	z12	Freely programmable
	E15	+	z14	Freely programmable
	E16	+	z16	Freely programmable
	E9...E16	GND	z18	
Status	Relay R1	NC contact NO contact Pole	d24 d26 d22	

## Socket connector, 5 interfaces

### COM2 and COM3 communication, E-LAN, time/trigger bus

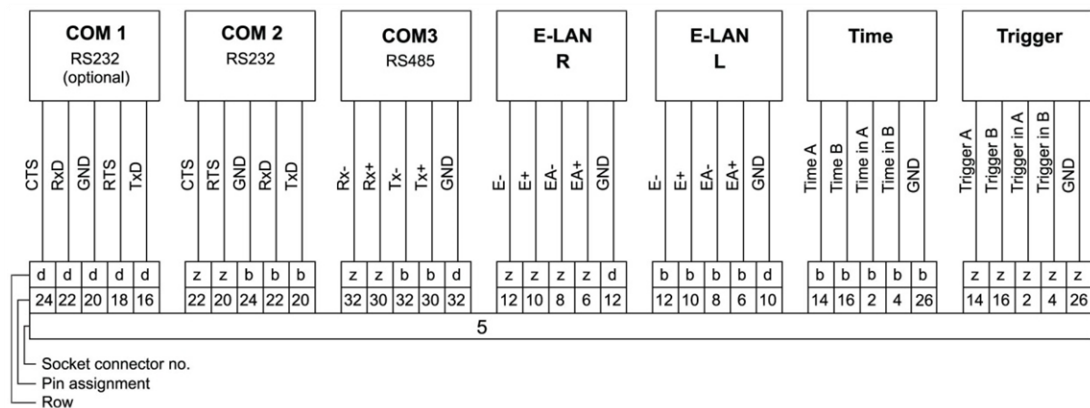

Designation	Function	Pin
COM 1 RS 232	CTS	d24
	RxD	d22
	GND	d20
	RTS	d18
	TxD	d16
COM 2 RS 232	CTS	z22
	RTS	z20
	GND	b24
	RxD	b22
	TxD	b20

COM 3 RS 485	Rx -	z32
	Rx +	z30
	Tx -	b32
	Tx +	b30
	GND	d32
E-LAN R (right)	E-	z12
	E+	z10
	EA-	z8
	EA+	z6
	GND	d12
E-LAN L (left)	E-	b12
	E+	b10
	EA-	b8
	EA+	b6
	GND	d10
Time	Time A	b14
	Time B	b16
	Time in A	b2
	Time in B	b4
	GND	b26
Trigger	Trigger A	z14
	Trigger B	z16
	Trigger in A	z2
	Trigger in B	z4
	GND	z26

# Block diagrams

## Block diagram feature C10 / M00, M96

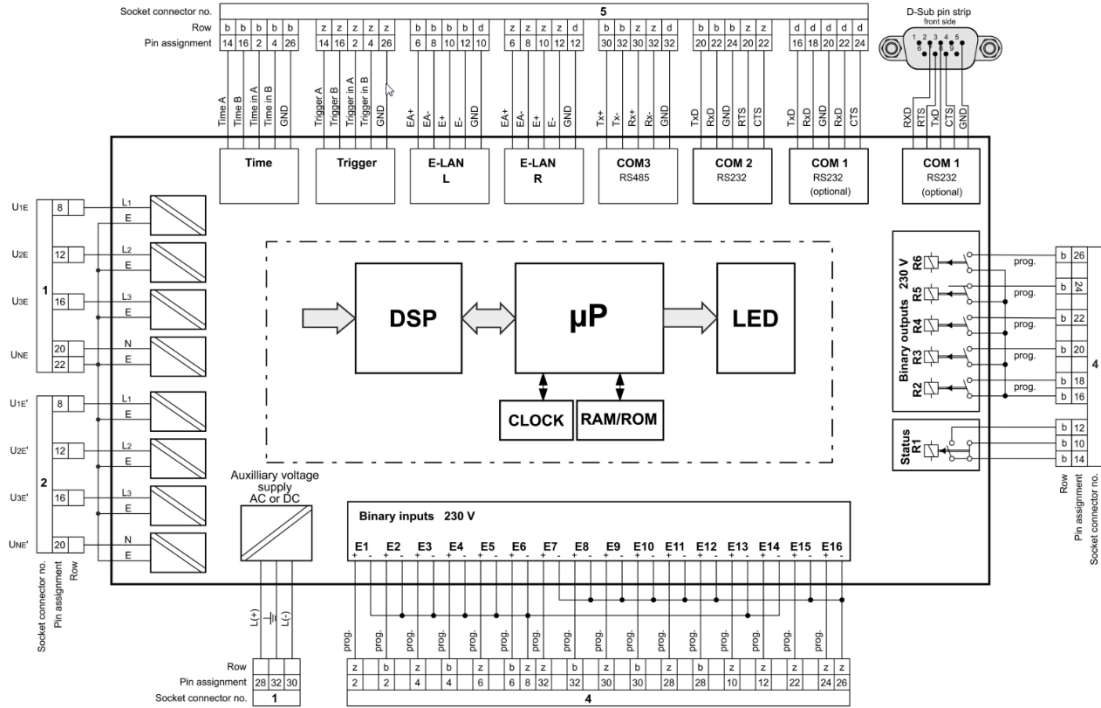

## Block diagram feature C10 / M92

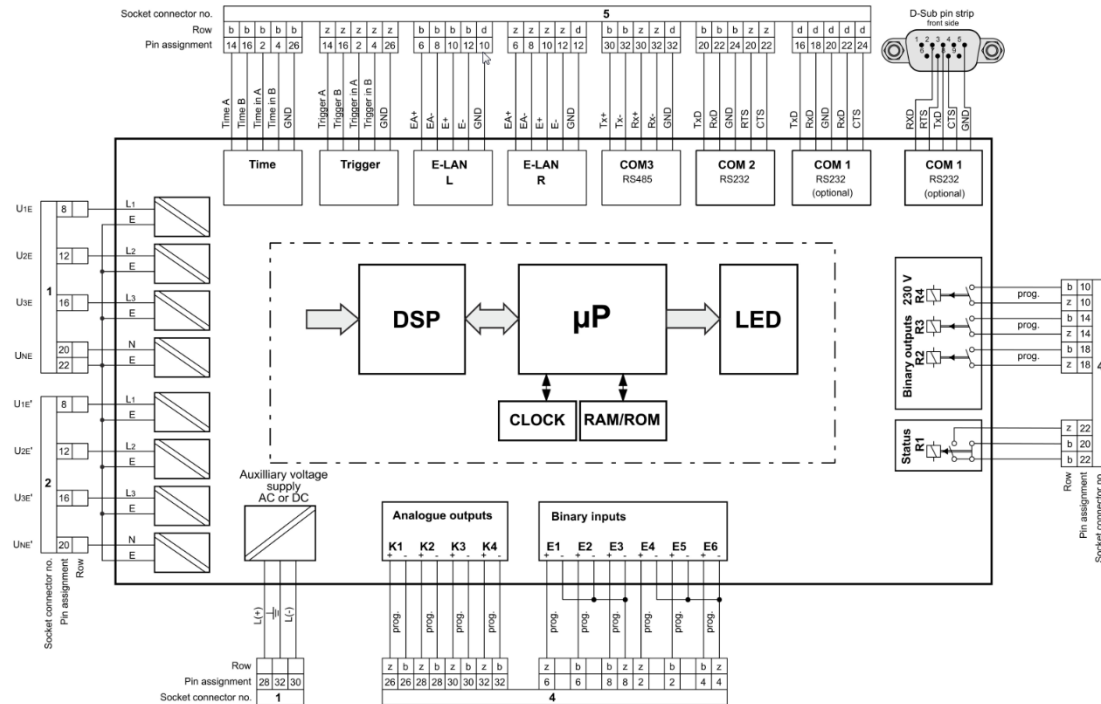

## Block diagram feature C10 / M93

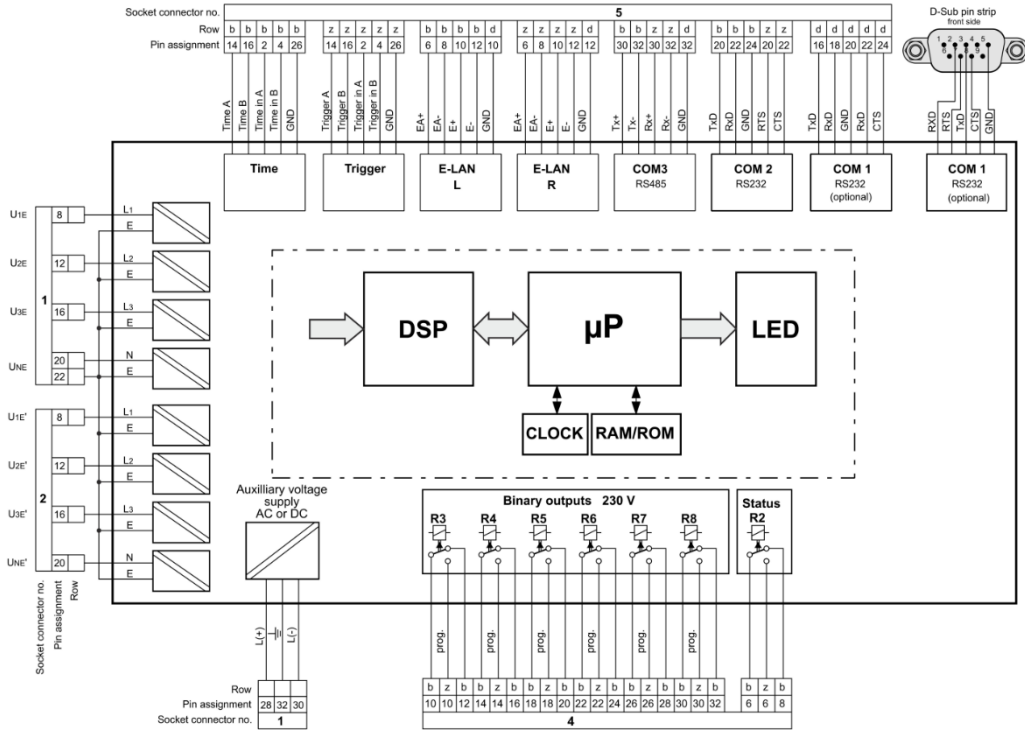

## Block diagram feature C10 / M94

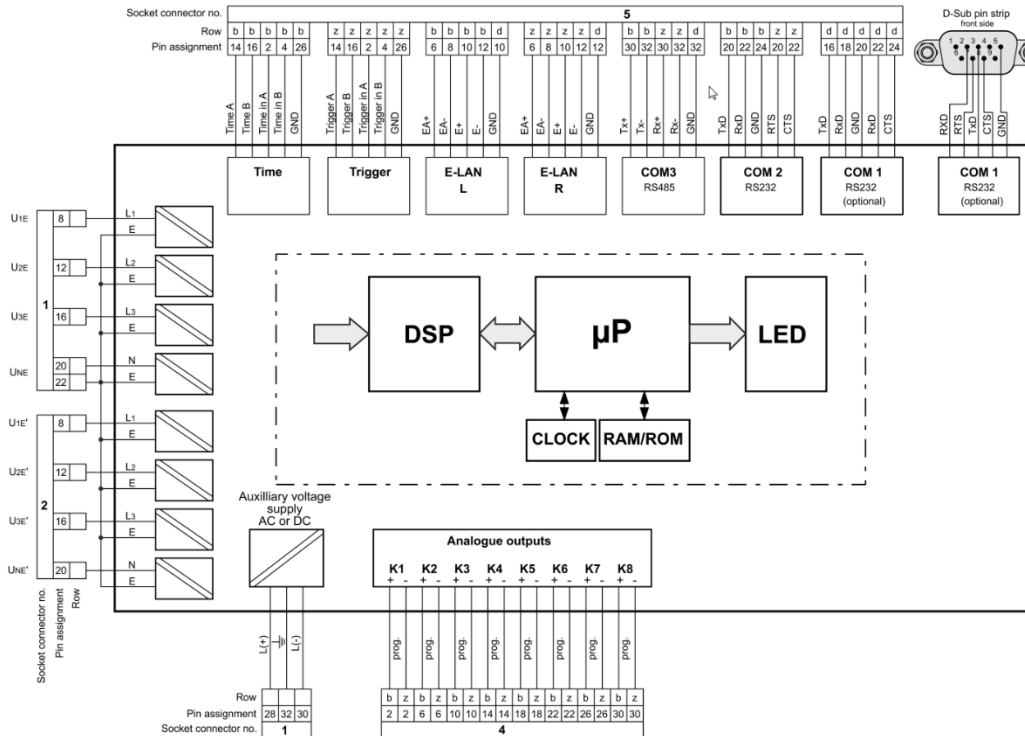

## Block diagram feature C20...C31 / M95





## RS232 interfaces

The PQI-D has two RS232 interfaces (COM1, COM2). COM1 is accessible via the D-Sub socket on the front of the device or via the screw terminals / D-Sub socket on the housing; COM2 is accessed via the screw terminals or the D-Sub on the housing.

COM2 is used to connect the regulating system to higher-level control systems or modems.

### Connection elements

<b>COM1</b>	Pin strip, Sub Min D on the front of the device, pin assignment the same as on PC
<b>COM2</b>	Terminal strip 5
Connection possibilities	PC, terminal, modem, PLC
Number of data bits / protocol	Parity 8, even, off, odd
Transfer rate bit/s	1200, 2400, 4800, 9600, 19200, 38400, 57600, 76800, 115200
Handshake	RTS / CTS or X <sub>ON</sub> / X <sub>OFF</sub>

## RS485 interfaces

Each PQI-D is equipped with a double E-LAN interface as standard. This provides bus connections to other PQI-Ds, to REG-D voltage regulators, EG-DP Petersen coil regulators and the EORSys earth fault locating system.

## E-LAN (Energy - Local Area Network)

The PQI-D is equipped with a double E-LAN L, R interface as standard. It is used to provide a network connection to other PQI-DAs or other REGSys™ devices from **A. Eberle GmbH & Co. KG**.

## Features

- 255 bus stations can be addressed
- Multimaster log based on SDLC/HDLC
- Repeater function between E-LAN interfaces L and R
- Adjustable transfer rate up to 375 kBaud
- 2-wire mode (multi-drop, RS485) or 4-wire mode (peer-to-peer, RS422)
- Switchable termination

## Operation

Up to 255 REGSys™ devices can communicate with each other on an E-LAN.

Access to the overall system network is possible from each RS232 or TCP/IP interface of the networked stations, for example to make settings on individual devices or to access data.

## Topology

The E-LAN can be set up from one linear bus segment or a tree structure made up of several linear bus segments. Data transfer between two bus segments usually takes place via the two E-LAN interfaces of a bus station (repeater function).



**Closed loops are not permissible!**

## Bus segments

The length of each segment is limited to 1.2 km.

Termination must be activated in the stations at both ends of each bus segment and deactivated in all the other stations.



**Unused E-LAN interfaces must be terminated.**

The operating mode (2-wire/4-wire) and the transfer rate must be specified for each bus segment. These parameters must be set for all

E-LAN interfaces that are connected to this bus segment.

### **2-wire mode (multi-drop, RS485):**

Up to 32 devices can be operated in parallel on a linear bus segment. The stations share the available transfer capacity.

Only one station can send at a given time, while all other stations receive (half-duplex mode).

If one of a number of stations is removed, data transfer between the remaining stations on this segment usually remains intact (bus termination!).

The maximum baud rate is 125 kBaud.

**4-wire mode (peer-to-peer, RS422):**

2 devices are connected via one segment; the wire pairs for sending and receiving must be crossed in this mode.

Both devices have the full transfer capacity and can send simultaneously (full-duplex mode).

If a station is removed, data transfer is interrupted.

The maximum baud rate is 375 kBaud.

Converter - booster

If distances of > 1.2 km are spanned, or if existing transmission lengths are to be used, a bus segment can be set up in 4-wire mode with the two interconnected bus converters (e.g. RS422<->optical fibre) of the transmission length.

Bus IDs



**Each E-LAN station must be assigned a unique address**

**(A...A9, B...B9, C...C9.....Z...Z4).**

System planning

Topology planning becomes more and more important as the data quantity to be transferred and the number of stations increase and as the expected response times of the system decrease.

Please note that all stations that are connected to a bus segment or to be accessed via an RS232 or TCP/IP interface share the transfer capacity of the respective data channel.

Which data quantity of which devices is accessed at which devices is an important consideration. The data quantity to be accessed via one interface should be restricted.

The maximum amount of data on one bus segment should not exceed the transfer capacity. In this regard, 4-wire mode is superior to 2-wire mode.

### Schematic representation of E-LAN options

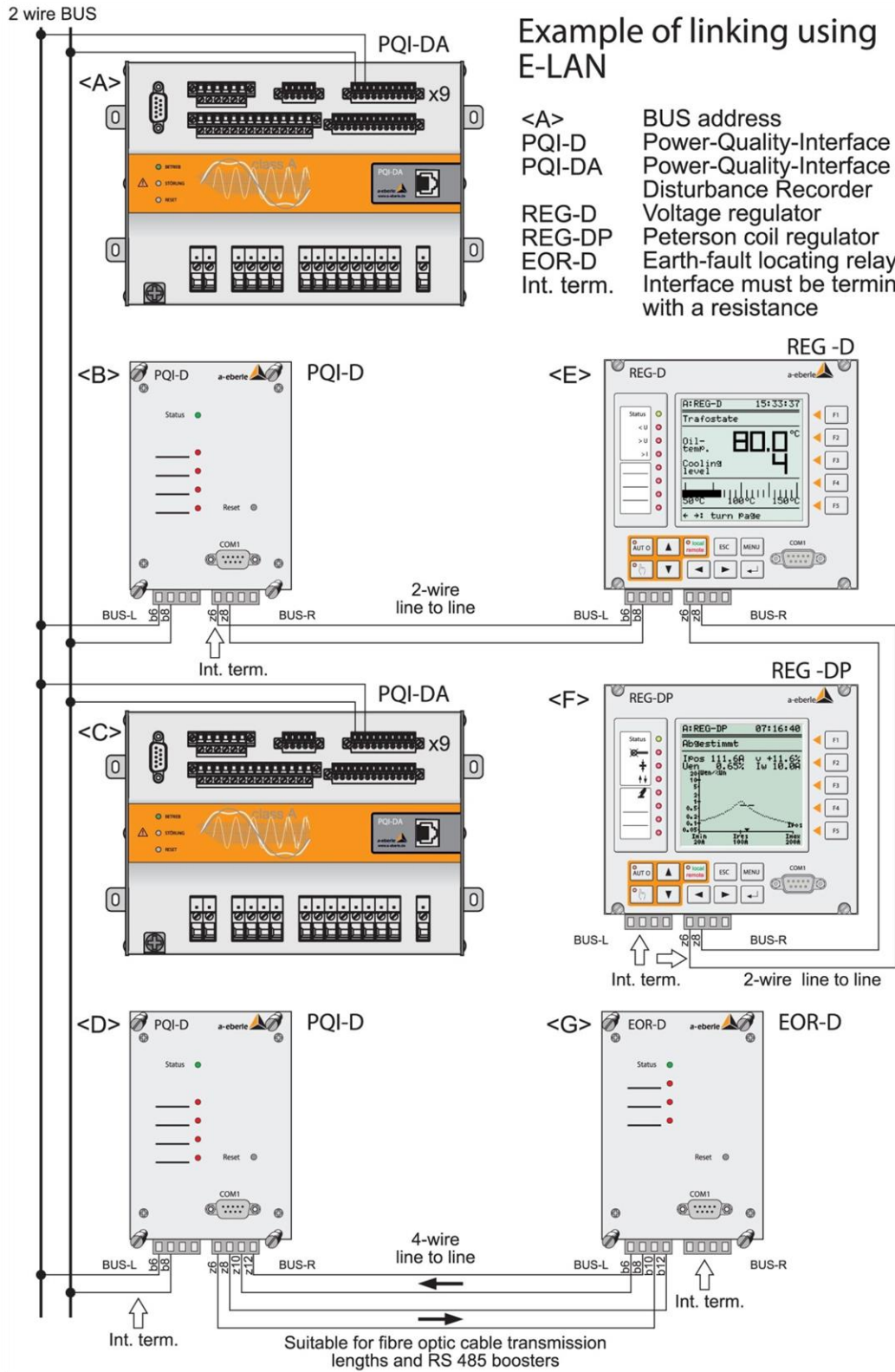

### Example of linking using E-LAN

- <A> BUS address
- PQI-D Power-Quality-Interface
- PQI-DA Power-Quality-Interface & Disturbance Recorder
- REG-D Voltage regulator
- REG-DP Peterson coil regulator
- EOR-D Earth-fault locating relay
- Int. term. Interface must be terminated with a resistance

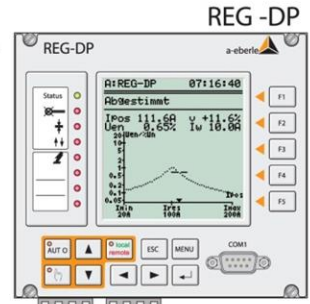
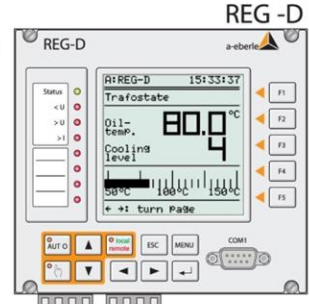

For connection of  $\leq 8$  interface modules (BIN-D, ANA-D) in any combination to any PQI-D.

## Time and trigger bus

Several devices can be accurately synchronised via the time bus.

The trigger bus makes it possible to trigger a device on the basis of an event on another measuring device.

## Time synchronisation

The PQI-D has an accurate quartz real-time clock (RTC), which continues to run on a backup battery if the auxiliary voltage is interrupted. The synchronisation of multiple devices is achieved by linking the PQI-Ds via the time synchronisation bus (RS 485).

One device is configured as the time master and transfers its system time cyclically to the other PQI-Ds (time slaves). The real-time clocks of the synchronised PQI-Ds thus follow that of the PQI-DA master precisely. PQI-Ds that are not connected via the time synchronisation bus are configured as time masters.

- ▶ **Information on setting up the time synchronisation when setting up the software and hardware is given in the relevant sections of the commissioning instructions.**

External radio times signals must supply a DCF77 signal and can be connected to a PQsys system in one of two different ways:

### RS232 interface of the time master (COM):

If a radio clock with a DCF77 output signal (DCF77 radio clock or GPS radio clock with DCF77 output signal) is connected to the RS232 interface, and if this is set to receive this signal, the time master sends the received signal to the time synchronisation bus, which synchronises all further PQI-Ds.

### Time synchronisation bus (RS485):

The external GPS radio clock (NIS Time GPS) can be connected directly to the time bus and then functions as the time master, i.e. all PQI-Ds connected to the time synchronisation bus are configured as time slaves.

The time synchronisation bus is designed as a 2-wire bus (A, B with GND).

The identically named connections A, B and GND are looped through from device to device.

Active termination must be applied at the end of one bus (even when there is only one PQI-D) by connecting the corresponding device A with Term\_A and device B with Term\_B.

If the bus length is  $> 1.5\text{m}$ , the termination should also be connected to the other bus end.

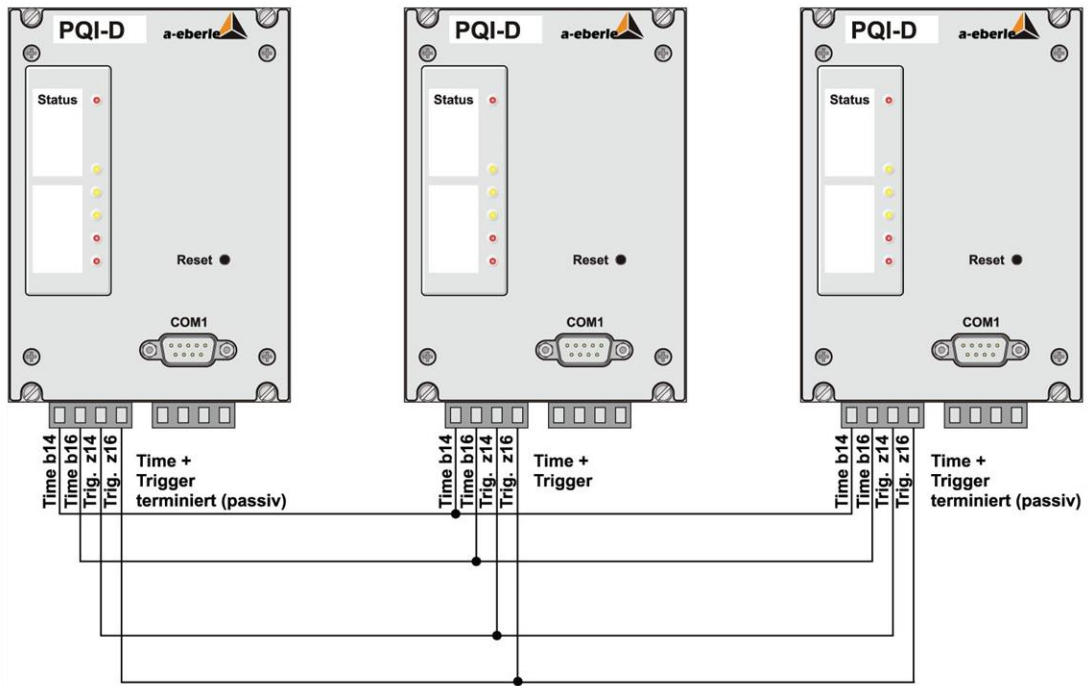

*Bus synchronisation, example of 3 PQI-Ds in two-wire connection*

### Termination – PQI-D bay

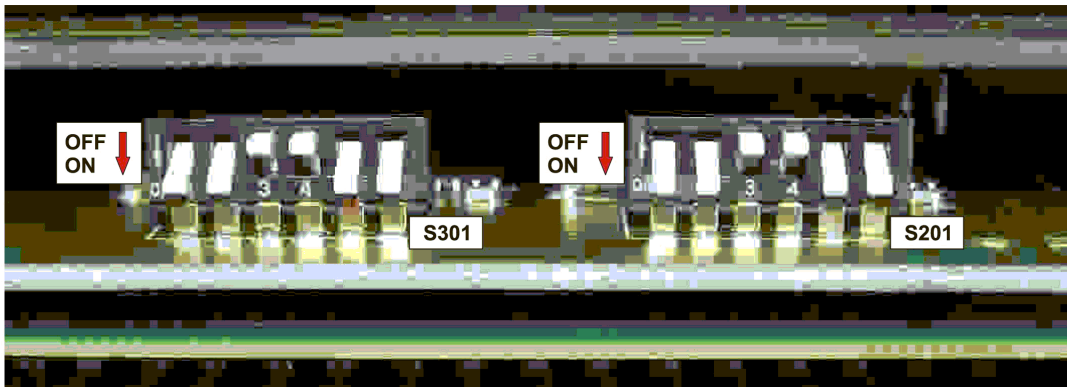

	2-wire						4-wire					
Termination time (S 301)	off	off	on	on	on	on	on	on	on	on	off	off
Termination trigger (S 201)	off	off	on	on	on	on	on	on	on	on	off	off
Without termination	off	off	off	off	on	on	off	off	off	off	off	off

## External trigger

The PQI-D can record fault records triggered by events. If several devices are interconnected via the trigger bus, each PQI-D can send a pulse that triggers simultaneous recording of fault records on the other bus stations when a trigger event occurs. This function can be activated/deactivated during setup.

The external trigger should always be activated if the exact time sequence of events is required.

The maximum length of a bus segment is 1.2 km in accordance with RS 485 standard; up to 32 devices can be connected. If the trigger bus is restricted to such a segment (within one wire), a 2-wire configuration (A, B and GND) is sufficient: At each device, RxA is connected to TxA and RxB to TxB.

The identically named connections RxA, RxB and GND are looped through from device to device.

Active termination must be applied at one end of the bus.

If the bus cable length is > 1.5m, termination of the PQI-D should also be connected at the other end of the bus.

If the trigger bus is made up of several segments that are connected via converters (e.g. FO star couplers), 4-wire operation (RxA, RxB, TxA, TxB with GND) is necessary:

The identically named connections xA, RxB, TxA, TxB and GND are looped through from device to device in each bus segment and connected to the corresponding signals of the converter at one end of the bus (Rx->TxD, Tx->RxD).

The Tx bus must be terminated actively at the first PQI-D.



## Voltage quality monitor

---

### Standard analysis

**Sources:** EN 50160, IEC 61000-4-30

- ▶ **Supply voltage (EN 50160):**  
R.m.s. value of the voltage at the transfer point
- ▶ **Agreed supply voltage  $U_c$  (EN 50160):**  
Nominal voltage, unless an alternative is agreed upon between the power supply company and the customer.
- ▶ **Normal operating conditions (EN 50160):**  
Describes the operating status in a distribution network in which current supply requirements are met, switching operations are carried out and faults are rectified using automatic protection systems without any unusual circumstances arising due to external influences or large bottlenecks in the supply.
- ▶ **Slow voltage change (EN 50160):**  
Changes in the r.m.s. value of the voltage due to changes in the load.
- ▶ **Fast voltage change (EN 50160):**  
An individual fast change in the r.m.s. value of the voltage between two successive voltage levels that each have a definite but non-specific length (DIN EN 61000-3-3, DIN EN 61000-4-15).
- ▶ **Flicker (EN 50160):**  
This describes fluctuations in the supply voltage which cause the visual brightness of an attached lamp to change by a certain amount.  
**Short-term flicker magnitude  $P_{st}$ :** 10-minute interval value  
**Long-term flicker magnitude  $P_{st}$ :** 2-hour average value of 12  $P_{st}$  values
- ▶ **Voltage dip (EN 50160):**  
Drop in the r.m.s. value of the voltage to 90%..1% of  $U_c$ .
- ▶ **Planned/random voltage interruption (EN 50160):**  
R.m.s. value of the voltage < 1% of  $U_c$ .  
Duration  $\geq 3$  minutes: Long-term interruption  
< 3 min: Short-term interruption
- ▶ **Intermittent overvoltage at the network frequency (EN 50160) :**  
R.m.s value of the voltage increases to > 170% of  $U_c$ .
- ▶ **nth order harmonic voltage :**  
Spectral components with a frequency n times the basic frequency of a periodic voltage.
- ▶ **THD (= Total Harmonic Distortion) :**

R.m.s. value of harmonic voltages  $n=2..40$  based on the r.m.s. value of the fundamental oscillation.

▶ **Network signal transfer voltage (EN 50160):**

R.m.s. value [%] of the ripple control signals of the audio frequency (110 Hz..3 kHz) or carrier frequency signals (3...148.5 kHz) based on  $U_c$ .

▶ **Voltage asymmetry:**

The degree to which the voltage vectors of the the fundamental oscillation differ from the symmetrical state of the 3-phase network (two successive phases having the same amplitude and phase difference) is measured using the relationship between the positive-system and negative-system components.

▶ **Voltage dip (IEC 61000-4-30) :**

Temporary drop in the voltage at a point in the electrical system below a threshold. An interruption is a special case of a voltage dip. Minimum voltage and the duration are essential characteristic values.

▶ **Voltage Swell (IEC 61000-4-30) :**

Temporary increase in the voltage at a point in the electrical system above a threshold. Maximum voltage and the duration are important characteristic values.

### Overview EN50160 (2010)

Characteristics of the voltage supply	Values / ranges of values		Measurement and evaluation parameters			
	Low voltage	Medium voltage	Basic quantity	Integration interval	Monitoring period	Required percentage
Frequency (when connected to an integrated network)	49.5 Hz to 50.5 Hz 47 Hz to 52 Hz		Average value	10 s	1 year	99,5 % 100%
Slow voltage change	230 V +10% / - 10%	$U_c$ +10% / - 10%	R.m.s. value	10 min	1 week	95% LV 99% MV
Fast voltage change	5%	4%	R.m.s. value	10 ms	1 day	100%
Flicker (specification only for long-term flicker)	P = 1		Flicker algorithm	2 h	1 week	95%
Voltage dips (< 1 min)	Tens to 1000 per year (under 85% $U_c$ )		R.m.s. value	10 ms	1 year	100%
Short interruption to the supply (< 3 min)	Tens to several hundred per year		R.m.s. value	10 ms	1 year	100%

Random long interruptions to the supply (>3 min)	Tens to 50 per year (under 1% $U_c$ )		R.m.s. value	10 ms	1 year	100%
Intermittent overvoltage at the network frequency (external conductor - earth)	Normally < 1.5 kV	1.7 to 2.0 $U_c$ (dependent on neutral point connection)	R.m.s. value	10 ms	None	100%
Transient overvoltage (external conductor - earth)	Normally < 6 kV	depending on isolation coordination	Peak value	None	None	100%
Voltage asymmetry (ratio of negative-sequence system to positive-sequence system)	Normally 2 % Up to 3 % in special cases		R.m.s. value	10 min	1 week	95%
Harmonic voltage (reference value $U_n$ or $U_c$ )	Total harmonic distortion (THD) = 8 %		R.m.s. value	10 min	1 week	95%
Interharmonic voltage	Values not yet available		Values not yet available			
Signal voltages (reference value $U_n$ or $U_c$ )	(MV: 9 to 95 kHz range not yet available)		R.m.s. value	3 s	1 day	99%

## Characteristics of the voltage supply

### Feature: Interruption to the supply

- Measurement quantities: Half-period r.m.s. voltage values
- Parameters: Threshold (EN 50160) =  $0.01 \cdot U_c$   
Maximum length of short interruptions to the supply (EN 50160) = 180 s
- Statistical quantities: Number and duration

Short interruptions to the supply :

Number per day, week and year

Integration over days, weeks and years

Long interruptions to the supply:

Number per day, week and year

Integration over days, weeks and years

- Reference values for number per year according to EN 50160:  
Short interruption to supply: "Tens to several hundred", default value = 30  
Long interruption to supply: "Fewer than 10 to 50", default value = 10

**Feature: Slow voltage change**

- Event: 10-minute interval with range exceeded
- Measurement quantities: 10-minute average values of the r.m.s. voltage values
- Parameters :  
Thresholds (EN 50160) =  $(1 \pm 0.1) \cdot UC$   
Default value of lower threshold:  $0.9 \cdot UC$   
Default value of upper threshold:  $1.1 \cdot UC$
- Statistical quantities:  
Number per day, week and year
- Max. relative frequency at each weekly interval  
according to EN 50160: 5%  
Default value: 5%

**Feature: Voltage dip**

- Measurement quantities: Half-period r.m.s. voltage values
- Parameter:  
Threshold (EN 50160) =  $0.01..0.90 \cdot UC$ , default value =  $0.90 \cdot UC$
- Statistical quantities: Number and duration  
Number per day, week and year  
Integration over days, weeks and years
- Reference value for number per year according to EN 51060:  
"Tens to 1000", default value = 100

**Feature: Intermittent overvoltage at the network frequency between the outer conductor and earth**

- Measurement quantities: Half-period r.m.s. voltage values
- Parameters: Threshold (EN 50160) =  $1.7..2.0 \cdot UC$ , default value =  $1.7 \cdot UC$
- Statistical quantities: Number and duration  
Number per day, week and year  
Integration over days, weeks and years
- Reference value for number per year according to EN 50160: None  
default value = 10

**Feature: Fast voltage change**

- Measurement quantities: Half-period r.m.s. voltage values
- Parameter:  
Threshold (EN 50160) =  $\pm 0.04..0.06 \cdot UC$   
default threshold value =  $0.06 \cdot UC$   
Minimum duration of stationary status, default value = 1 s
- Statistical quantities: Number and duration  
Number per day, week and year  
Integration over days, weeks and years

- Reference value for number per day according to EN 51060:  
"Several possible", default = 10  
Number per year: Default value = 3650

**Feature: Voltage asymmetry**

- Event: 10-minute interval with range exceeded
- Measurement quantities: 10-minute average value for voltage asymmetry
- Parameters: Threshold (EN 50160) = 2..3%  
Default value: 2%
- Statistical quantities: Number per day, week and year
- Max. relative frequency at each weekly interval according to EN 50160: 5%  
Default value: 5%

**Feature: Harmonic voltages, THD**

- Event: 10-minute interval, range of at least one harmonic voltage or the THD is exceeded.
- Measurement quantities: 10-minute average values of harmonic voltages (r.m.s.), THD
- Parameters :  
Thresholds (EN 50160) = harmonic: See table 2 in EN 50160 THD: 8%  
Default value: According to EN 50160
- Statistical quantities: Number per day, week and year
- Max. relative frequency at each weekly interval according to EN 50160: 5%  
Default value: 5%

**Feature: Network signal transfer voltages**

- Measurement quantities: 3-second average values of network signal transfer voltages (%)
- Parameter:  
Thresholds (EN 50160) = see Figures 1 and 2 in EN 50160  
Carrier frequency  
Default value: Carrier frequency = 168 Hz, threshold = 9 %
- Statistical quantities: Number and duration  
Number per day, week and year  
Integration over days, weeks and years
- Max. relative frequency at each daily interval according to EN 50160: 1%  
Default value: 1%

**Feature: Flicker**

- Event: 2-hour interval with range exceeded
- Measurement quantities: Long-term flicker magnitude  $P_{lt}$  (2-hour average value)
- Parameters: Threshold (EN 50160) = 1.0  
Default value: 1.0
- Statistical quantities: Number per day, week and year
- Max. relative frequency at each weekly interval according to EN 50160: 5%  
Default value: 5%

**Feature: Network frequency, narrow range**

- Measurement quantities: 10-second average value
- Parameter:  
Thresholds (EN 50160, synchronised connection to the integrated network) = 50 Hz,  $\pm$  0.5 Hz  
Default value of lower threshold = 49.5 Hz  
Default value of upper threshold = 50.5 Hz
- Statistical quantities: Number and duration  
Number per day, week and year  
Integration over days, weeks and years
- Reference value for relative frequency per year according to EN 50160: 0.5%  
Default value: 0.5%

**Feature: Network frequency, wide range**

- Measurement quantities: 10-second average value
- Parameters:  
Thresholds (EN 50160, synchronised connection to the integrated network) = 47 Hz, 52 Hz  
Default value of lower threshold = 47.0 Hz  
Default value of upper threshold = 52.0 Hz
- Statistical quantities: Number and duration  
Number per day, week and year  
Integration over days, weeks and years
- Reference value for relative frequency according to EN 50160: 0%  
Default value: 0%

## Network quality events

.The features of the supply voltage are measured in the corresponding aggregation intervals and monitored with the (adjustable) network quality tolerance thresholds.

If the tolerance ranges are violated, network quality events are produced, recorded, and their duration and frequency accumulated at certain intervals.

The data acquired in this way are so compact that they can be recorded autonomously over longer periods. Event processing is a multi-level procedure that comprises the production, evaluation and recording of events.



In 3-conductor systems, only the voltage between the outer conductors are monitored according to EN50160.

In 4-conductor systems, the voltages between the outer conductors and the neutral conductor are also monitored. Limit value monitoring is carried out with hysteresis (exception: fast voltage change)

The events are first generated separately for each of the phase voltages being monitored ("phase events").

There are two basic types for aggregation of events over time

Interval events

Start/stop events

Evaluation of the network quality is based on network events that are produced by combining the phase events of a feature.

Depending on the type, events can be represented as one or several event entries with the same format:

Time stamp : time at which the event was triggered

Identifier : indicates type

Event value : dependent on the type of event

## Interval events

These events are generated at the end of the measurement interval when a limit violation occurs for the following supply voltage features measured as 10-minute or 2-hour values.

Slow voltage deviation (10-minute values)

Harmonics, THD (10-minute values)

Asymmetry (10-minute value)

Flicker (2-hour values)

If the limit value is continuously violated, the event is generated again each time the interval elapses. The event value corresponds to the interval measurement value.

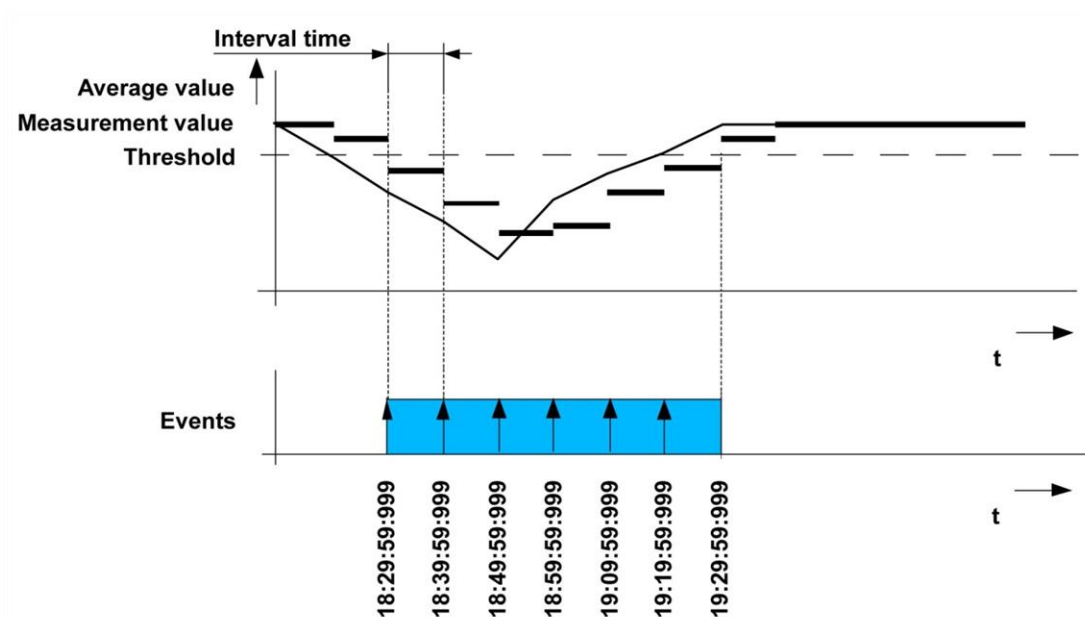

The first phase event of the interval to be detected is interpreted as a network event.

Each network or phase event requires 1 event entry.

The network events are counted at daily, weekly and yearly intervals for each of these features.



## Start / stop events

These events are generated for the following supply voltage features:

Fast voltage change (10-ms values):

Dip (10-ms values)

Swell (10-ms values)

Voltage dip (10-ms values)

Transient overvoltage at the network frequency (10-ms values):

Voltage interruption (10-ms values)

Signal overvoltage (150/180-period values)

Frequency deviation, narrow tolerance (10-second values)

Frequency deviation, wide tolerance (10-second values)

The event start entry is generated at the beginning of each limit violation, and the event stop entry at the end. The WinPQ evaluation software determines the time difference between the start and stop event, and displays the respective duration and extreme values for the event.

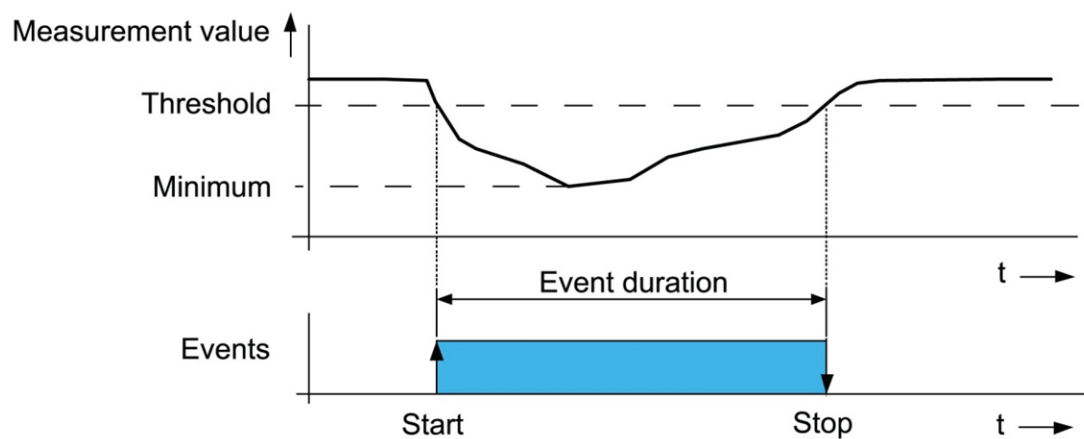

It is possible to record either phase events or network events.

Network events are generated by combined evaluation of phase events (exception: frequency deviation). The OR connection applies when the above-mentioned phase events are combined, with the exception of voltage interruption, i.e. the network event is active for as long as a phase event is active on at least one of the monitored phase voltages.

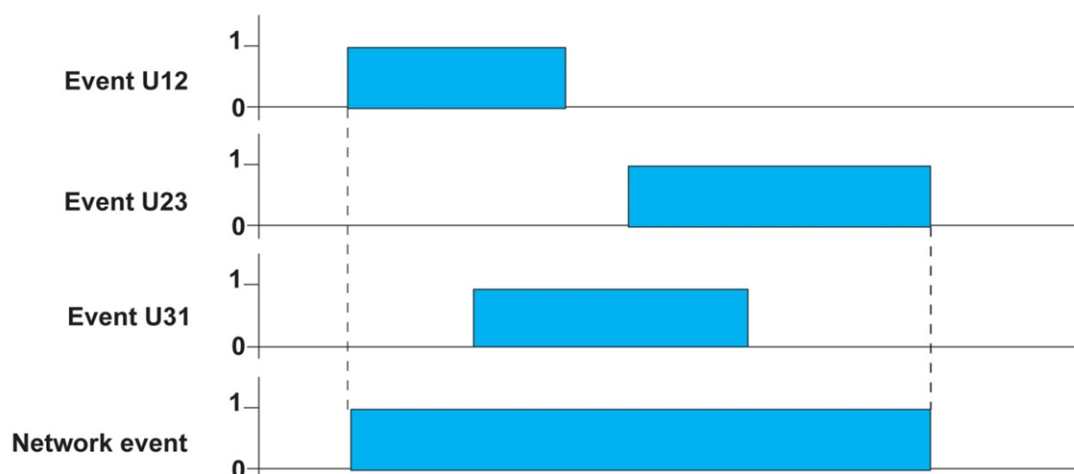

### Prioritising events

Faults in the supply voltage can affect a variety measurement quantities at the same time, and can trigger overlapping limit violations. In order to distinguish between dominant primary fault events and secondary effects at all times, the start/stop events are prioritised according to the scheme below. If an event occurs at any time while an event with higher priority is active, the event with the lower priority is rejected.

Event with higher priority	Voltage interruption	Voltage dip	Overvoltage	Voltage change	Frequency deviation
Event					
Voltage change	✓	✓	✓		
Voltage dip	✓	✓			
Voltage swell	✓		✓		
Voltage dip	✓				
Overvoltage	✓				
Voltage interruption					
Signal voltage	✓			✓	
Frequency deviation, narrow range	✓			✓	✓
Frequency deviation, wide range	✓			✓	

## Flagging

The PQI-DA network analyser flags measurement intervals in accordance with IEC 61000-4-30, Class A.

Flags are generated for events that are based on the 10-ms r.m.s. values of the voltage.

The events are classified according to 3 fault levels:

### Level Event

0	None
1	Fast voltage change, dip, swell
2	Voltage dip, overvoltage
3	Voltage interruption

For each phase voltage, the maximum fault level that occurs in each of the measurement intervals (10/12 periods, 150/180 periods, 10-minute, 2-hour) is recorded and stored in a status word in the interval data. By combining the maximum interval fault level with an adjustable threshold, it is determined whether the events of the following features based on the interval measurement values are evaluated or rejected:

- Signal voltages (150/180-period values)
- Network frequency (10-second value)
- Slow voltage deviation (10-minute values)
- Harmonics, THD (10-minute values)
- Asymmetry (10-minute value)
- Flicker (2-hour values)

The setting "Flagging from..." (WinPQ) sets the fault level from which the events listed above are rejected. 10-minute and 2-hour events can only be rejected with the setting "Flagging from interruption" is selected (factory setting).

## Binary event notification signals

The network events generate binary notification signals, which can be output via binary outputs, for example.

## Aggregation of statistical values

The network events for the power supply feature are counted at daily, weekly and yearly intervals and the time sums calculated.

Events are assigned to the day on which they were completed.

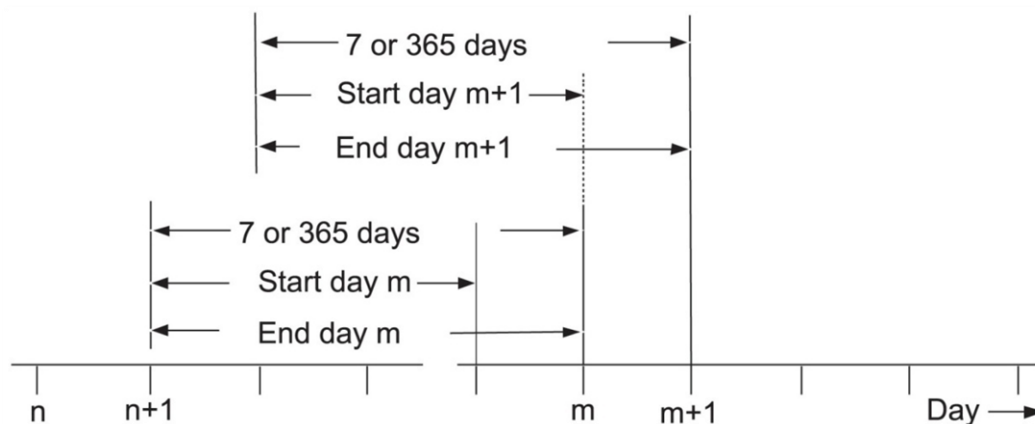

At the end of the day, the weekly and yearly values from the last 7 or 365 days are calculated and stored.

## Monitoring statistical values

The statistical values are monitored on the base of limit values (adjustable).

If these limit values are exceeded, corresponding binary notification signals are generated (see 4.10):

Narrow frequency tolerance range too frequently exceeded [week]

Narrow frequency tolerance range too frequently exceeded [year]

Maximum number of intermittent overvoltages at the network frequency exceeded [year]

Maximum number of fast voltage changes exceeded [day]

Maximum number of fast voltage changes exceeded [year]

Maximum number of voltage dips exceeded [year]

Maximum number of short supply interruptions exceeded [year]

Maximum number of long supply interruptions exceeded [year]

Slow voltage change range exceeded too frequently [week]

Harmonic distortion range exceeded too frequently [week]

Asymmetrical voltage range exceeded too frequently [week]

Flicker range exceeded too frequently [week]

Signal voltage exceeded too frequently [day]

Signal voltage exceeded too frequently [week]

Maximum number of days with exceeded signal voltage exceeded [year]

## Controlling the event evaluation

Evaluation is initially disabled at the factory. It is activated via software when all settings have been made and valid measurement signals are present.

When a binary input is selected ( $> 0$ ), the statistical evaluation of network quality events is interrupted during log "high".

The evaluation disable via software has a higher priority than the binary input.

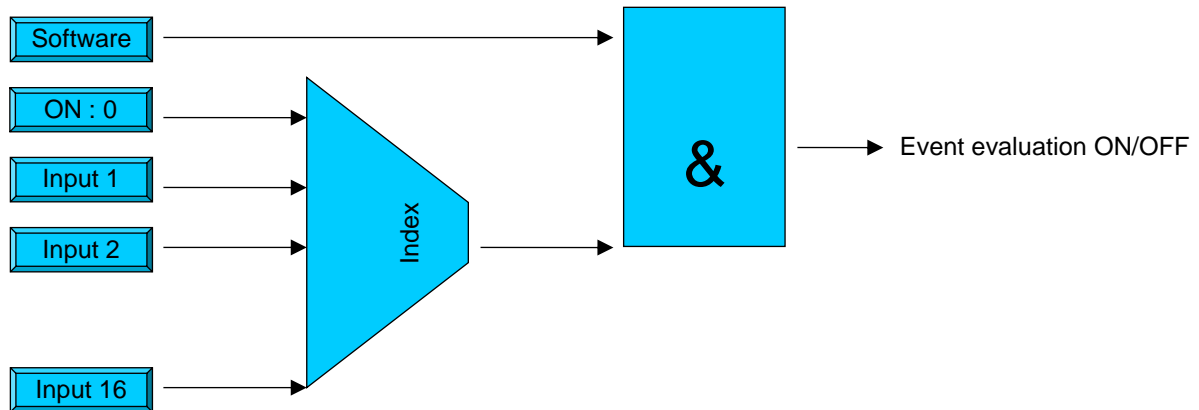

## Basic setting for PQI-D

The factory settings have been selected in such a way that only a few parameters need be modified in most applications.

A PQI-D with 400 V voltage inputs is configured for a typical low-voltage network (EN5160 400V.def). If the PQI-D is equipped with 100 V inputs, it is preset at the factory for a typical medium-voltage network (EN50160 1kV-35kV.def).

## Measurement circuits

### Transformer configuration

In general:

- If the neutral earth voltage  $U_{NE}$  is not available, terminal "N" must be connected to "E".
- The parameterisation software is used to help choose the type of connection.
- The voltage transformer configuration and current transformer configuration can be parameterised completely independently of one another and can thus be adjusted to any network situation.



**Note:** The software user interface offers the easiest possible method for carrying out this procedure.

## Connection possibilities

Terminal assignment for PQI-D voltage and current inputs

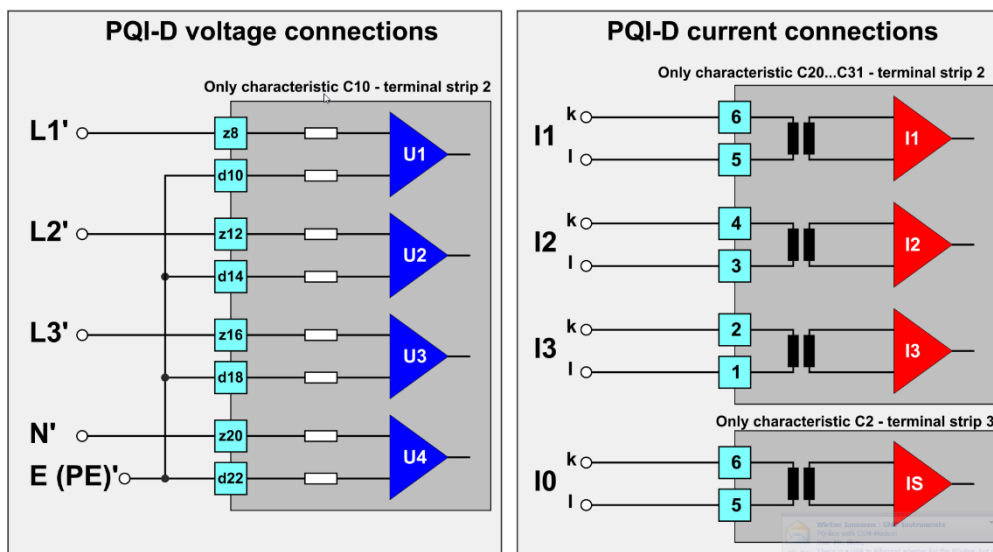

## Current transformer connections

Each PQI-D power quality interface has four current inputs. In general, inputs I1 to I3 can be used to measure the conductor currents.

The fourth current can be used as a sum current or as a neutral conductor current input.

For sum current measurements, it does not matter whether the sum current is created using a sum current transformer (core balance transformer) or a Holm-Green circuit.

Only two currents are required in an Aron circuit because, in “healthy” three-conductor networks (in which the vector sum of all three currents is zero), the third current can be calculated if the other two currents are already known.

Normally, an Aron circuit is applied in such a way that the currents in L1 and L3 are measured and are then used to calculate L2.

The PQI-D is not limited in this case either, since the appropriate input configuration is prepared regardless of which phases have a current transformer available.

## PQI-D current transformer connection

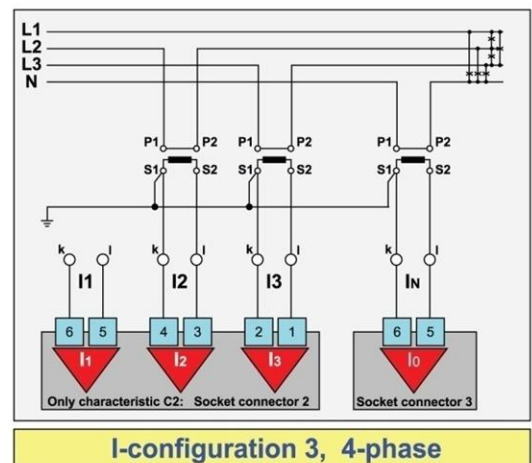
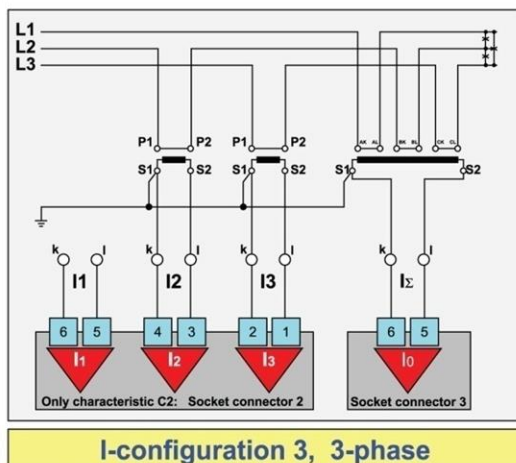
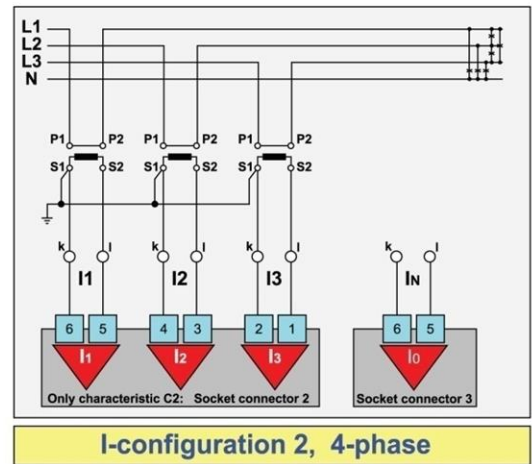
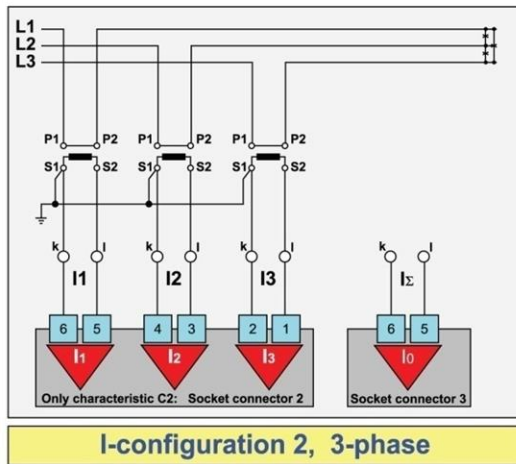
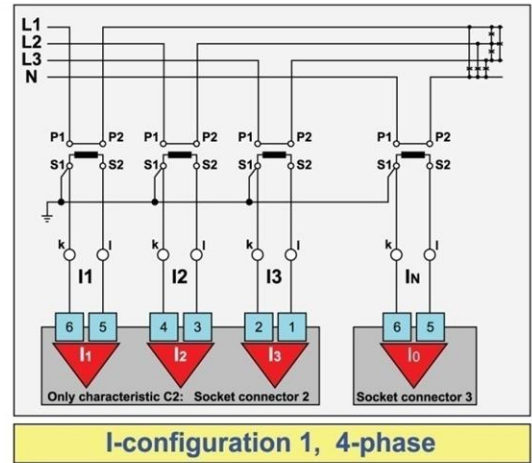
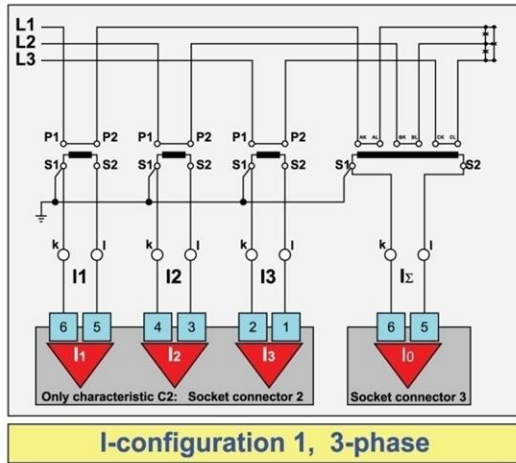



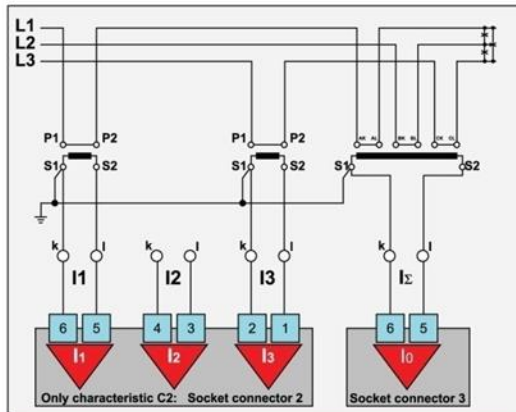

I-configuration 4, 3-phase

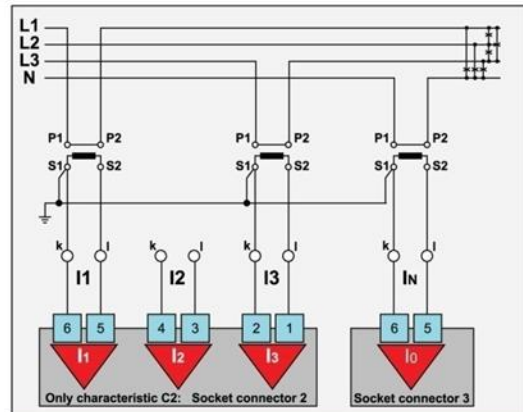

I-configuration 4, 4-phase

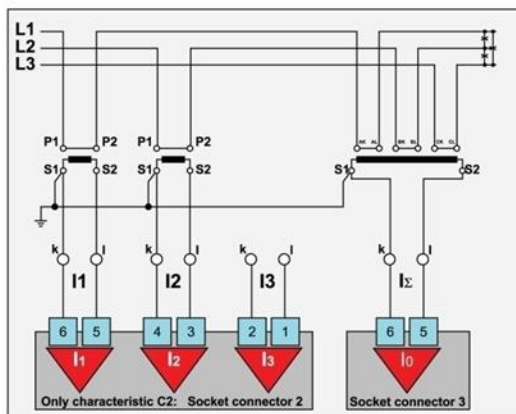

I-configuration 5, 3-phase

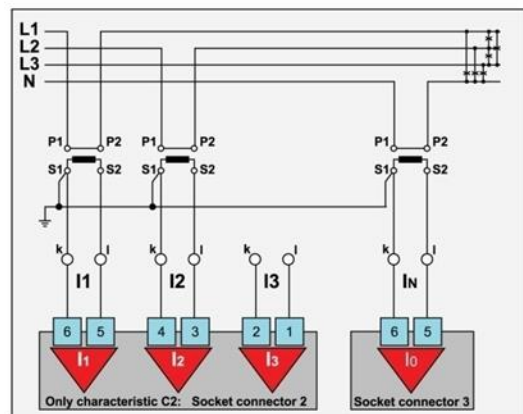

I-configuration 5, 4-phase

## Voltage transformer connections

The PQI-D provides different configurations for voltage measurement.

The specific situation in the system generally determines which type of connection should be used. Three single-pole and two double-pole isolated voltage transformers can be used.

The fourth measurement input is required for measuring the neutral earth voltage  $U_{NE}$ .



**Note:** The PQI-D can also calculate the neutral earth voltage from the three phase voltages; it is therefore not essential for the neutral earth voltage to be physically connected. The fourth input can thus be used for a different voltage measurement, which will deliver additional information.

## Voltage transformer connection PQI-D



**Note:** If  $U_{NE}$  is not required, both terminals for the  $U_{NE}$  input must be short-circuited.

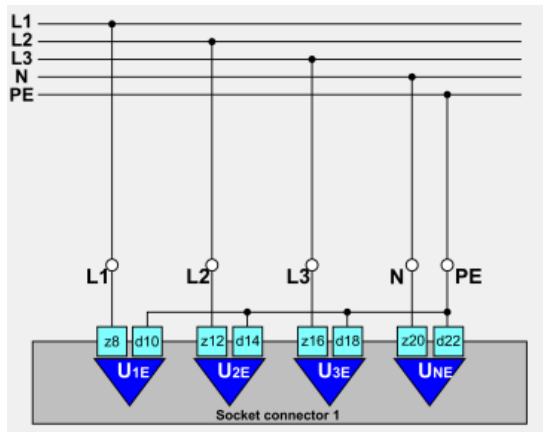

**U-configuration 1, 4-phase**

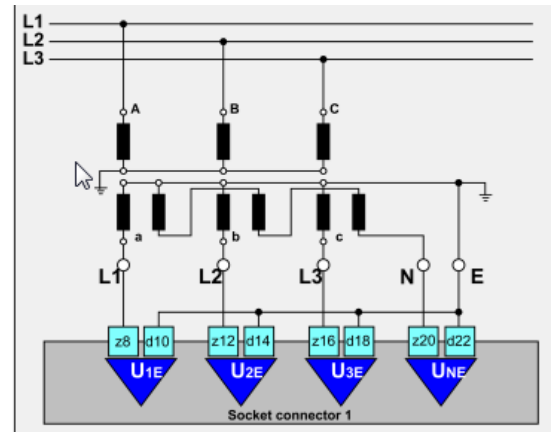

**U-configuration 1, 3-phase**

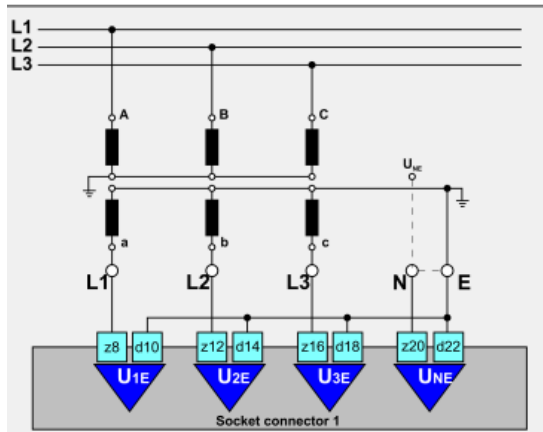

**U-configuration 2**

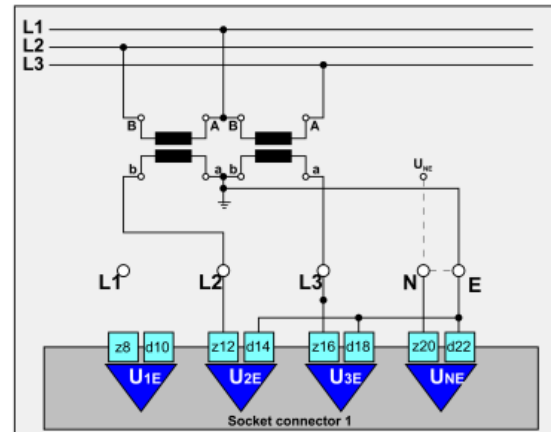

**U-configuration 3**

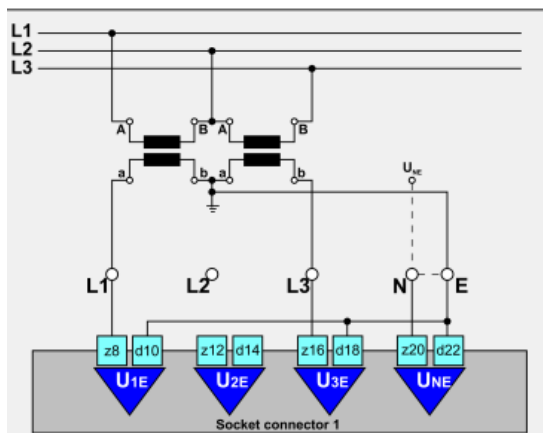

**U-configuration 4**

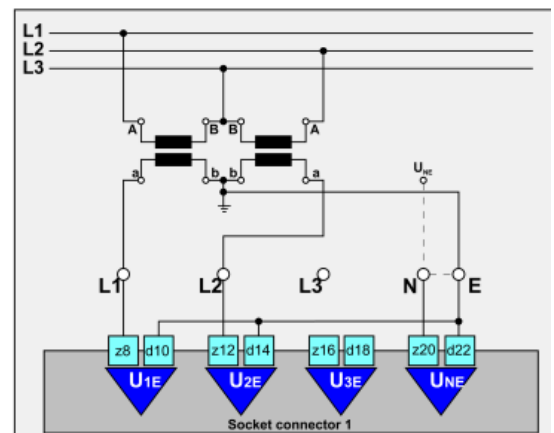

**U-configuration 5**

## Reference voltage

U12 is set as the reference voltage at the factory. Any other voltage can also be defined as the reference voltage. All absolute phase angles are based on this voltage.

The reference voltage is also used for frequency measurement.



**In the 8xU version, the reference voltage is monitored and, if it fails, automatically switched to the corresponding voltage of the other line, if one is available.**

## Network frequency

The nominal network frequency can be set to 50 Hz or 60 Hz.

The factory setting is 50 Hz.

Changes do not become effective until the device is restarted.

## System time

The system time is set at the factory and is protected against unintentional adjustment; the time zone is CET and summer/winter switching for CEST is activated.

If the local time zone does not match the one set at the factory, the setting can be changed at any time.



**Adapting the time to the local time zone must never be carried out manually!**

The maximum time deviation in non-synchronised mode is 1 minute/month. When the time setting is protected, the device accepts only changes within +/-250ppm based on the time elapsed since the last correction. The time accuracy of  $\pm 20\text{ms}$  required by DIN IEC 61000-4-30, Class A dictates the need for synchronisation by an external real-time clock with DCF77 output (SPACE format) (refer to 6.4). In synchronised mode, the manual time setting is blocked.

## Binary inputs

One use of the bipolar binary inputs is to control recording, statistical evaluation and synchronisation of average values in the power intervals. If option M96 is present, the sampling rate of the binary inputs is 10.24 KHz. For other measurement cards (M00 and M94), the measurement interval is 4 milliseconds. The names of the binary inputs can be configured freely and are displayed with the fault records.

## Binary outputs

Each binary output (relay) can be controlled by an output function that can be assigned up to 32 binary notification signals.

The logic level of the OR connection of these signals is debounced using the adjustable delay time ( $T_h$ ) and the operating mode, and output with a configured switching state.

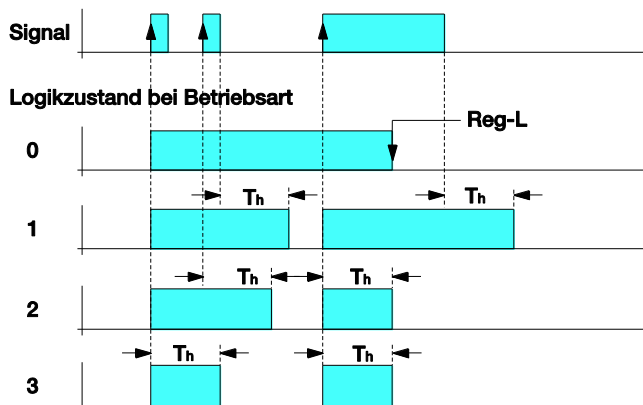

Operating mode	Designation
0	Bistable, edge trigger, set/delete via REG-L
1	Monostable, level re-trigger
2	Monostable, edge re-trigger
3	Monostable, no re-trigger

The status relay is always preassigned the corresponding system error notification signals at the factory.

Without notification signals assigned, the binary outputs can be triggered directly in mode 0 using REG-L commands.

## Analogue outputs

With hardware options M94 and M95, it is possible to use the device as a measurement transducer and output selected measurement values as an analogue signal.

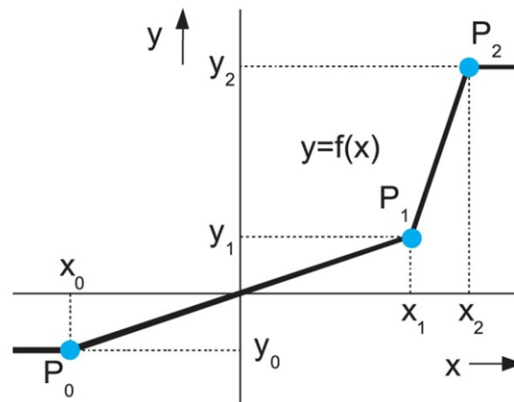

- Parameterisation regulations :  $x_0 < x_1 < x_2$   
 Limit :  $y(x < x_0) = y_0$      $y(x > x_2) = y_2$   
 Scaling of the x-axis : as the input measurement quantity  
 Scaling of the y-axis : normalised to the analogue output quantities,  
 e.g. 1 corresponds to 20 mA

## Analogue inputs

The M97 and M98 measurement cards allow four additional analogue input signals to be recorded. Current signals from -20 mA up to +20 mA can be recorded and scaled freely.

**Example:** Wind speed, radiation, temperature etc.

## LED display

Five LEDs on the PQI-D can be freely parameterised and linked with messages and events.

## Synchronisation of interval average power values

In order to record the 15-minute power interval synchronously with a counter, for example, you can choose between internally generated time intervals and a trigger binary input.

Factor setting : internal 15-minute interval

## Data management

---

When the PQI-D is operating, it generates a large amount of continuous and event-triggered data, of which only a certain proportion can be measured and saved within a limited time period. The length of the saving process is dependent on the amount to be saved, as well as on how often the data are transferred to the PC database.

The selection and the method of displaying the measurement data must be configurable so that the **device memory** and **transfer capacity** resources can be used as flexibly and efficiently as possible. All the configuration parameters are stored in the device and can be read, so that the measurement data are uniquely identifiable at all times when accessed using a PC.

The following distinctions must be made:

- Settings (configuration parameters)
- System data
- Interval measurement data
- Event-triggered measurement data (fault recorder)
- Statistical measurement data
- Binary messages (signals)

### Measurement data classes

Interval	Data class	Maximum number of channels	Data types	Data quantity [bytes]/ (day * measurement channel)
10/12 periods ≈200 ms	C_s2_1	8	Average values	1.73 MB
	C_s2_2			
150/180 periods ≈3s	C_3s_1	256	Average values	115 kbytes
	C_3s_2			
10 minutes	C_10m_1	1024	Average values	576 bytes
	C_10m_2		Extreme values	1728 bytes
2 hours	C_2h_1	256	Average values	48 bytes
	C_2h_2			

Each data class is made up of an adjustable number of recording points, the memory requirement being proportional to the number of recording points.

One of two operating modes for recording may be selected:

**Linear:**

When the set number of recording points is reached, further entries are rejected.

**Circular:**

When the set number of recording points is reached, the oldest recording point is overwritten with the newest one.

## Memory configuration

For optimum utilisation of the measurement data memory, it can be fully or partially re-configured by the user.

The following basic rules then apply:

Each allocated data class occupies a contiguous block of memory (no segmentation). Utilisation of free memory outside the allocated block is not possible.

Data classes can only be allocated or removed individually and consecutively.

Allocation is carried out according to the "first-fit" procedure, in which a new data class is inserted at the beginning of the first sufficiently large, contiguous segment of free memory (starting at the lowest memory address).

If only single data classes are newly allocated or removed, fragmentation of free memory will usually result.

Contiguous memory allocation can only be forced by first deleting all data classes and then re-allocating them individually.

The memory contents of a data class (including the recorder background memory) can be deleted while upholding the allocation, or the recording can be interrupted.

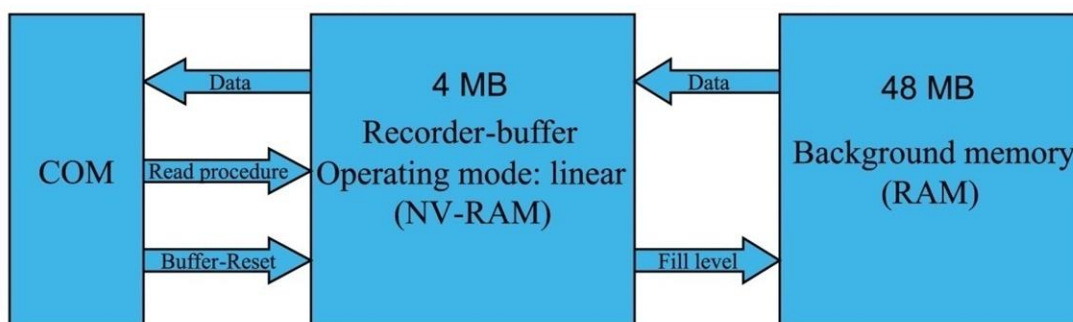

Besides the non-volatile NV RAM, a volatile background memory is also available in the considerably larger SDRAM for the recording of fault records. All fault records are initially recorded in the background memory. In order for them to be accessed from the device via the communication interface, they must be shifted to the NV RAM.

In circular buffer mode, new fault records are shifted to the NV RAM buffer immediately, since the oldest entry is always overwritten by the newest one, irrespective of whether it could be read via the communication interface beforehand.

For this reason, the buffer for recorders A, B and S is set to linear mode at the factory. Fault records are shifted from the background memory to the NV RAM buffer until the latter is full. Further fault records are initially stored in the background memory. As soon as the NV RAM buffer has been accessed, the corresponding memory is released and the next fault records are shifted from background memory to NV RAM buffer. This ensures that no fault record can be overwritten before it has been accessed.



## Definition of the measurement quantities

The figure below illustrates the basic quantities for measurements in 3-conductor, three-phase current systems; the designations are based on DIN 40110-2 "Quantities used in alternating current theory - Part 2: Multi-line circuits".

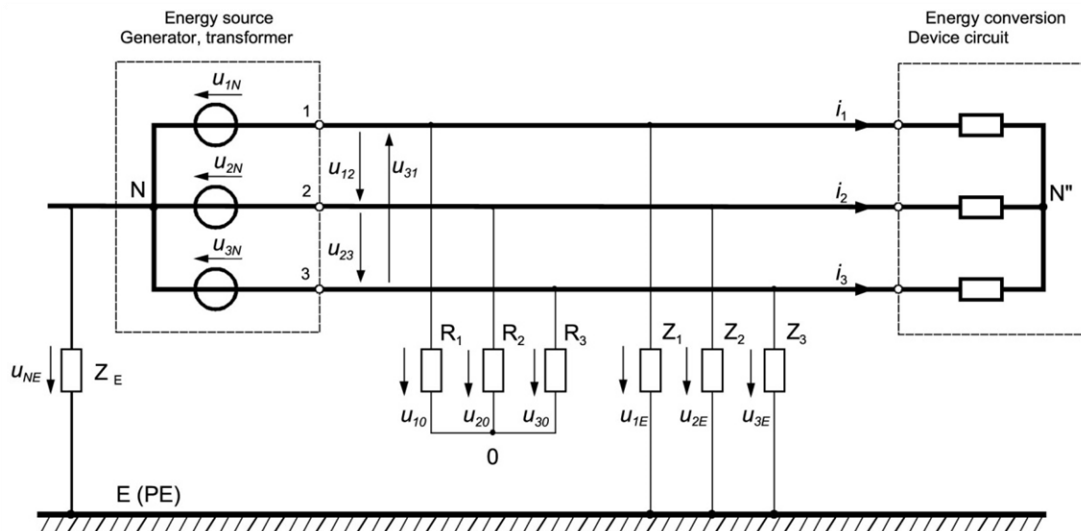

### Sampling values

The measurement signals are first filtered through anti-aliasing low pass filters.

The signals, now limited to a measurement bandwidth of roughly 4 kHz, are then sampled by an A/D converter (ADC) with a 24-bit resolution and a constant frequency of 10.24 kHz.

The ADC sampling values are recorded in the oscilloscope recorder.

### Half-period values

The half-period values are formed at every half-period from the last two half-wave values.

## R.m.s. values

Half-wave r.m.s. values:

$$X_{rms(T/2)} = \sqrt{\frac{\sum_{n=1}^N w_n \cdot x_a^2(n)}{\sum_{n=1}^N w_n}}$$

Half-period r.m.s. value:

$$X_{rms(1/2)} = \sqrt{\frac{\sum_{n=1}^2 X_{rms(T/2)}^2(n)}{2}}$$

## Arithmetic average values

Arithmetic half-wave average value:

$$X_{(T/2)} = \frac{\sum_{n=1}^N w_n \cdot x_a(n)}{\sum_{n=1}^N w_n}$$

Arithmetic half-period average value:

$$X_{(1/2)} = \frac{\sum_{n=1}^2 X_{(T/2)}(n)}{2}$$

## Synchronised sampling values

From the ADC sampling values, 2048 equidistant synchronised sampling values are computed for each 10/12-period interval.

## 10/12-period values

The 10/12-period values are calculated from the synchronised sampling values  $x_s(n)$ .

R.m.s. values

$$X_{rms-10/12} = \sqrt{\frac{\sum_{n=1}^{2048} x_s^2(n)}{2048}}$$

Arithmetic average values

$$X_{10/12} = \frac{\sum_{n=1}^{2048} x_s(n)}{2048}$$

## 150/180-period values

The 150/180-period values are calculated from the  $N$  10/12-period values of a 150/180-period interval.

R.m.s. values

$$X_{rms-150/180} = \sqrt{\frac{\sum_{n=1}^N X_{rms-10/12}^2(n)}{N}}$$

Arithmetic average values

$$X_{150/180} = \frac{\sum_{n=1}^N X_{10/12}(n)}{N}$$

## 10-minute values

The 10 minute values are calculated from the N 10/12-period values of each 10-minute interval, and are calculated synchronously with the 10-minute limits of the system time. Each 10/12-period value is included exactly once in a 10-minute value calculation.

R.m.s. values

$$X_{rms-10min} = \sqrt{\frac{\sum_{n=1}^N X_{ms-10/12}^2(n)}{N}}$$

Arithmetic average values

$$X_{10min} = \frac{\sum_{n=1}^N X_{10/12}(n)}{N}$$

## 2-hour values

The 2-hour values are calculated from the N 10-minute values of each 2-hour interval, and are calculated synchronously with the 2-hour limits of the system time. Each 10-minute value is included exactly once in a 2-hour value calculation.

R.m.s. values

$$X_{rms-2h} = \sqrt{\frac{\sum_{n=1}^N X_{rms-10min}^2(n)}{N}}$$

Arithmetic average values

$$X_{2h} = \frac{\sum_{n=1}^N X_{10min}(n)}{N}$$

## Sampling values

### Primary sampling values

With the exception of the V circuit, the measurement signals from the conductor-ground voltages and conductor currents are sampled.

### Phase-to-phase sampling values

The phase-to-phase sampling values are calculated from the primary values of the following relationships.

External conductor voltages

$$u_{12}(n) = u_{1E}(n) - u_{2E}(n) = -(u_{23}(n) + u_{31}(n))$$

$$u_{23}(n) = u_{2E}(n) - u_{3E}(n) = -(u_{31}(n) + u_{12}(n))$$

$$u_{31}(n) = u_{3E}(n) - u_{1E}(n) = -(u_{12}(n) + u_{23}(n))$$

Neutral earth voltage of the virtual neutral point to earth (3-conductor system)

$$u_{0E}(n) = \frac{u_{1E}(n) + u_{2E}(n) + u_{3E}(n)}{3}$$

Phase voltages to the virtual neutral point (3-conductor system)

$$u_{10}(n) = \frac{u_{12}(n) - u_{31}(n)}{3}$$

$$u_{20}(n) = \frac{u_{23}(n) - u_{12}(n)}{3}$$

$$u_{30}(n) = \frac{u_{31}(n) - u_{23}(n)}{3}$$

Outer conductor-neutral conductor voltages (4-conductor system)

$$u_{1N}(n) = u_{1E}(n) - u_{NE}(n)$$

$$u_{2N}(n) = u_{2E}(n) - u_{NE}(n)$$

$$u_{3N}(n) = u_{3E}(n) - u_{NE}(n)$$

Sum current, conductor currents (3-conductor system)

$$i_E(n) = i_1(n) + i_2(n) + i_3(n)$$

$$i_1(n) = i_E(n) - (i_2(n) + i_3(n))$$

$$i_2(n) = i_E(n) - (i_3(n) + i_1(n))$$

$$i_3(n) = i_E(n) - (i_1(n) + i_2(n))$$

Neutral conductor current, external conductor currents (4-conductor system)

$$i_N(n) = -(i_1(n) + i_2(n) + i_3(n))$$

$$i_1(n) = -(i_N(n) + i_2(n) + i_3(n))$$

$$i_2(n) = -(i_N(n) + i_3(n) + i_1(n))$$

$$i_3(n) = -(i_N(n) + i_1(n) + i_2(n))$$

## R.m.s. voltage values

All sampling values are included in the same way when calculating the r.m.s. values. Measurement value aggregation is carried out according to (10.1).

## Negative deviation, positive deviation

Negative deviation and positive deviation are calculated from the corresponding r.m.s. voltage values in [%] of the agreed voltage in accordance with DIN EN 61000-4-30.

## R.m.s. current values

All sampling values are included in the same way when calculating the r.m.s. values. Measurement value aggregation is carried out according to (10.1).

## Network frequency

The network frequency is calculated from the duration T of N of the periods that are fully contained in a 10-second interval.

$$f_{10s} = \frac{N}{T}$$

The 10-minute and 2-hour values of the network frequency are calculated as arithmetic average values according to (9.1).

## Spectral analysis

Please also refer to: EN 61000-4-7

The spectral components of all voltages and currents are calculated from the 2048 sampling values of each 10/12-period interval using an FFT algorithm.

## R.m.s. values of the harmonic subgroups

The r.m.s. values of the harmonic subgroups are calculated from the spectral components in accordance with EN 61000-4-7.

The r.m.s. values of the harmonic subgroups of the voltages are normalised to the r.m.s. value fundamental oscillation and transferred in [%], i.e. multiplied by 100.

The r.m.s. value of harmonic subgroup 1 consequently always has the value 100%.

The r.m.s. values of the harmonic subgroups are transferred in [A].

The aggregation of the 150/180-period, 10-minute and 2-hour r.m.s. values is carried out according to (10.1).

## R.m.s. values of the interharmonic subgroups

The r.m.s. values of the interharmonic subgroups are calculated from the spectral components in accordance with EN 61000-4-7.

The r.m.s. values of the interharmonic subgroups of the voltages are normalised to the r.m.s. value fundamental oscillation and transferred in [%], i.e. multiplied by 100.

The r.m.s. values of the interharmonic subgroups are transferred in [A] .

The aggregation of the 150/180-period, 10-minute and 2-hour r.m.s. values is carried out according to (10.1).

## Harmonic distortions

The measurement quantities for distortion are calculated from the r.m.s. values  $U_n$ ,  $I_n$  of the harmonic subgroups.

The 150/180-period, 10-minute and 2-hour values are calculated from the corresponding r.m.s. values of the harmonic subgroups.

## Total Harmonic Distortion (THDS)

Voltages:

$$THDS = \sqrt{\sum_{n=2}^{40} U_n^2}$$

Currents:

$$THDS = \frac{\sqrt{\sum_{n=2}^{40} I_n^2}}{I_1}$$

The values are transferred in [%], i.e. multiplied by 100.



## Partial Weighted Harmonic Distortion (PWHD)

Voltages:

$$PWHD = \sqrt{\sum_{n=14}^{40} n \cdot U_n^2}$$

Currents:

The values are transferred in [%], i.e. multiplied by 100.

$$PWHD = \frac{\sqrt{\sum_{n=14}^{40} n \cdot I_n^2}}{I_1}$$

$$K = \frac{\sum_{n=1}^{40} (n \cdot I_n)^2}{\sum_{n=1}^{40} I_n^2}$$

K factor

The values are transferred in [%], i.e. multiplied by 100.

## Total Harmonic Current (THC)

$$THC = \sqrt{\sum_{n=2}^{40} I_n^2}$$

## Partial Odd Harmonic Current (PHC)

$$PHC = \sqrt{\sum_{n=21,23}^{39} I_n^2}$$

## Signal voltage

The 10/12-period r.m.s. value of the signal voltage based on the reference voltage is calculated from the spectral components of the 10/12-period FFT using either one of the two methods in DIN EN 61000-4-30.

The signal frequency can be selected within the measurement bandwidth.

The output is in [%].

The 10/12-period r.m.s. value is stored event-triggered in recorder S in accordance with DIN EN 61000-4-30.

The 150/180-period r.m.s. value is formed according to (10.1) and is a feature of the supply voltage (DIN 50160).

## Phase of the voltages, currents to reference voltage (fundamental oscillation)

The 10/12-period value of the phase of the fundamental oscillations of the voltages and currents based on the reference voltage is calculated from the phase angles of the corresponding spectral components.

The phase angle of the reference voltage is consequently always 0°.

The 150/180-period, 10-minute and 2-hour values are calculated as arithmetic average values according to (10.1).

## Phase of the phase voltages to associated conductor currents (fundamental oscillation)

The 10/12-period value of the phase of the fundamental oscillations of the phase voltages based on the associated conductor currents is calculated from the phase angles of the corresponding spectral components.

The 150/180-period, 10-minute and 2-hour values are calculated as arithmetic average values according to (10.1).

## Phase of the current harmonics to the phase voltage fundamental oscillation

For the 2nd..40th harmonics of the conductor currents, the phase shift (+/- 180°) of the zero point is calculated based on the zero point of the fundamental oscillation of the associated phase voltage (10/12-period value).

The 150/180-period, 10-minute and 2-hour values are calculated as arithmetic average values according to (10.1).

## Symmetrical components, asymmetries, phase sequence

The value and phase of the positive, negative and zero-sequence system component for voltages and currents are calculated from the corresponding spectral components of the fundamental oscillation.

Positive-sequence system:

$$\underline{U}_{1\_PS} = \frac{1}{3} \cdot (\underline{U}_{1N-1} + \underline{a} \cdot \underline{U}_{2N-1} + \underline{a}^2 \cdot \underline{U}_{3N-1})$$

$$\underline{I}_{1\_PS} = \frac{1}{3} \cdot (\underline{I}_{1-1} + \underline{a} \cdot \underline{I}_{2-1} + \underline{a}^2 \cdot \underline{I}_{3-1})$$

Negative-sequence system:

$$\underline{U}_{1\_NS} = \frac{1}{3} \cdot (\underline{U}_{1N-1} + \underline{a}^2 \cdot \underline{U}_{2N-1} + \underline{a} \cdot \underline{U}_{3N-1})$$

$$\underline{I}_{1\_NS} = \frac{1}{3} \cdot (\underline{I}_{1N-1} + \underline{a}^2 \cdot \underline{I}_{2N-1} + \underline{a} \cdot \underline{I}_{3N-1})$$

Zero-sequence system:

$$\underline{U}_{ZS} = \frac{1}{3} \cdot (\underline{U}_{1N-1} + \underline{U}_{2N-1} + \underline{U}_{3N-1})$$

$$\underline{I}_{ZS} = \frac{1}{3} \cdot (\underline{I}_{1N-1} + \underline{I}_{2N-1} + \underline{I}_{3N-1})$$

with

Rotation operator:

$$\underline{a} = e^{j120^\circ \cdot ROT}$$

The phase differences between the corresponding symmetrical components of voltage and current are also calculated.

The 150/180-period, 10-minute and 2-hour values of the amounts are calculated as r.m.s. values, and those of the phases are calculated as arithmetic average values according to (10.1).

The negative-sequence system asymmetry is calculated from the negative-sequence and positive-sequence system components.

Voltage:

$$u_2 = \frac{|U_{1\_NS}|}{|U_{1\_PS}|}$$

Current:

$$u_2 = \frac{|I_{1\_NS}|}{|I_{1\_PS}|}$$

The zero-sequence system asymmetry is calculated from the zero-sequence and positive-sequence system components.

Voltage

$$u_0 = \frac{|U_{ZS}|}{|U_{1\_PS}|}$$

Current

$$u_0 = \frac{|I_{ZS}|}{|I_{1\_PS}|}$$

All asymmetry values are transferred in [%], i.e. multiplied by 100.

The 150/180-period, 10-minute and 2-hour values are calculated as arithmetic average values according to (10.1).

When calculating the symmetrical components, the direction of rotation *ROT* is selected in such a way that the positive-sequence component of the voltage is larger than the negative-sequence system component.

ROT = +1 : phase sequence 123

ROT = -1 : phase sequence 321

## Power measurement quantities

### Active powers

The 150/180-period, 10-minute and 2-hour values of the active powers are calculated as arithmetic average values according to (10.1).

### Collective half-period active power

The collective half-period active power  $P_{\Sigma(1/2)}$  is calculated as an arithmetic half-period average value of the collective present power  $p_{\Sigma}(n)$  according to (10.1.2.2) and recorded in recorder B.

$$p_{\Sigma}(n) = u_{1E/N}(n) \cdot i_1(n) + u_{2E/N}(n) \cdot i_2(n) + u_{3E/N}(n) \cdot i_3(n)$$

In 3-conductor systems, the phase voltages correspond to the conductor-earth voltages; in 4-conductor systems, they correspond to the voltages of the external conductors to the neutral conductor.

### 10/12-period active powers

The 10/12-period values of the active powers of the phases  $P_{L-10/12}$  are calculated as arithmetic average values from the present powers  $p_L(n)$  of the phase voltages and the corresponding conductor currents according to (10.1.4.2).

$$p_L(n) = u_{L0/N}(n) \cdot i_L(n)$$

with L = phase index

In 4-conductor systems, the voltage between the external conductor and the neutral conductor is used as the phase voltage.

The collective active power is then:

$$P_{\Sigma-10/12} = P_{1-10/12} + P_{2-10/12} + P_{3-10/12}$$

In 3-conductor systems, the voltage between the conductor and the virtual neutral point is used as the phase voltage, so that the neutral earth voltage has no effect on the active power of the phase.

The "earth active power"  $P_{E-10/12}$  produced by the neutral earth voltage and earth current is

calculated separately as an arithmetic average value from the present powers  $p_E(n)$  of the neutral earth voltage and the earth current according to (10.1.4.2).

$$p_E(n) = u_{0E}(n) \cdot i_E(n)$$

The collective active power is then calculated as

$$P_{\Sigma-10/12} = P_{1-10/12} + P_{2-10/12} + P_{3-10/12} + P_{E-10/12}$$

The fundamental oscillation active power is calculated from the apparent power of the geometrical fundamental oscillation (refer to 10.9.2) as

$$P_{G-10/12} = \operatorname{Re}\{S_{G-10/12}\}$$

#### Interval average values of the active powers

The average values of the active powers of the phases and the collective active power are based on a definable time interval and transferred as events. The time interval can be triggered either externally (binary input/trigger command) or internally as a fixed cycle time.

## Apparent power

Collective apparent power according to DIN 40110-2:

$$S_{\Sigma} = U_{\Sigma} \cdot I_{\Sigma}$$

$$U_{\Sigma} = \frac{1}{2} \cdot \sqrt{U_{12}^2 + U_{23}^2 + U_{31}^2 + U_{1E/N}^2 + U_{2E/N}^2 + U_{3E/N}^2}$$

$$I_{\Sigma} = \sqrt{I_1^2 + I_2^2 + I_3^2 + I_{E/N}^2}$$

where

E = earth (3-conductor system)

N = neutral conductor (4-conductor system)

The collective apparent power according to DIN 40110-2 only corresponds to the sum of the apparent powers of the phases when perfect symmetry is given. It is greater under real asymmetrical conditions, since it also includes the coupling between the phases.

The 150/180-period, 10-minute and 2-hour values of the apparent power are calculated from the corresponding values of the input quantities.

Apparent power of the geometrical fundamental oscillation:

Calculation from the symmetrical components where

$$\underline{S}_G = 3 \cdot [\underline{U}_{1\_PS} \cdot \underline{I}_{1\_PS}^* + \underline{U}_{1\_NS} \cdot \underline{I}_{1\_NS}^* + \underline{U}_{1\_ZS} \cdot \underline{I}_{1\_ZS}^*]$$

Angle of the apparent power of the geometrical fundamental oscillation:

$$\varphi_G = \text{arc}\{\underline{S}_G\}$$

## Collective half-period apparent power

The collective apparent power according to DIN40110-2 is calculated from the half-period r.m.s. values of the voltages and currents and recorded in recorder B.

$$S_{\Sigma(1/2)} = U_{\Sigma(1/2)} \cdot I_{\Sigma(1/2)}$$

## 10/12-period apparent powers

The apparent powers of the phases are calculated from the corresponding 10/12-period r.m.s. values of the phase voltages and currents as

$$S_{L-10/12} = U_{L-10/12} \cdot I_{L-10/12}$$

In 3-conductor systems, the voltage between the conductor and the virtual neutral point is used as the phase voltage; in 4-conductor systems, the voltage between the external conductor and the neutral conductor is used.

The collective apparent power according to DIN40110-2 is calculated from the 10/12-period r.m.s. values of the voltages and currents.

$$S_{\Sigma(10/12)} = U_{\Sigma(10/12)} \cdot I_{\Sigma(10/12)}$$

The apparent power of the geometrical fundamental oscillation  $\underline{S}_{G-10/12}$  is calculated from the 10/12-period values of the symmetrical components.



## Reactive power

Given sufficiently sinusoidal voltages, the following applies for the collective overall reactive power:

$$Q_{tot,\Sigma} \approx \sqrt{Q_{1,\Sigma}^2 + D_{\Sigma}^2 + Q_u^2}$$

Given sufficiently sinusoidal voltages, the following applies for the total reactive powers of the phases:

$$Q_{tot,L} \approx \sqrt{Q_{1,L}^2 + D_L^2}$$

where

$Q_1$ : displacement reactive power of the fundamental oscillation

D: current distortion reactive power

$Q_u$ : asymmetry reactive power

The collective total reactive power only corresponds to the sum of the total reactive powers of the phases when perfect symmetry is given. It is greater under real asymmetrical conditions, since it also contains the asymmetry reactive power.

The sign of the displacement reactive power of the fundamental oscillation is applied to the reactive powers. The reactive power of the phases is  $\varphi_L$ : Phase difference between the phase voltage and the conductor current (fundamental oscillation)

for collective reactive powers

$\varphi_G$ : Angle of the apparent power for the geometrical fundamental oscillation.

The 150/180-period, 10-minute and 2-hour values of the reactive power are calculated from the corresponding values of the input quantities.

## Collective half-period total reactive power

The collective reactive power is calculated from the half-period values of the collective apparent power and the collective active power and recorded in recorder B.

$$Q_{tot,\Sigma(1/2)} = \text{Sgn}(\varphi_G) \cdot \sqrt{S_{\Sigma(1/2)}^2 - P_{\Sigma(1/2)}^2}$$

Total reactive power

Phase:

$$Q_{tot,L-10/12} = \text{Sgn}(\varphi_{L-10/12}) \cdot \sqrt{S_{L-10/12}^2 - P_{L-10/12}^2}$$

Collective:

$$Q_{tot,\Sigma-10/12} = \text{Sgn}(\varphi_{G-10/12}) \cdot \sqrt{S_{\Sigma-10/12}^2 - P_{\Sigma-10/12}^2}$$

Collective displacement reactive power of the fundamental oscillation

$$Q_{1,\Sigma-10/12} = \text{Im}\{S_{G-10/12}\}$$

Current distortion reactive power

Phase:

$$D_L = U_{L0/N-1} \cdot I_{D-L}$$

$U_{L0/N-1}$  : r.m.s. value of the fundamental oscillation of the phase voltage  
of external conductor  $L = \{1, 2, 3\}$  where

0 = virtual neutral point (3-conductor system)

N = neutral conductor (4-conductor system)

$I_{D-L}$  : distortion current of conductor L

$$I_{D-L} = \sqrt{I_L^2 - I_{L-1}^2}$$

$I_L$  : r.m.s. value of the conductor current

$I_{L-1}$  : r.m.s. value of the fundamental oscillation of the conductor current

Since the distortion current also contains the non-harmonic components, these are also included in the current distortion reactive power.

Collective:

$$D_{\Sigma} = U_{\Sigma-1} \cdot \sqrt{I_{D-1}^2 + I_{D-2}^2 + I_{D-3}^2 + I_{D-E/N}^2}$$

where

$$U_{\Sigma-1} = \frac{1}{2} \cdot \sqrt{U_{12-1}^2 + U_{23-1}^2 + U_{31-1}^2 + U_{1E/N-1}^2 + U_{2E/N-1}^2 + U_{3E/N-1}^2}$$

$U_{LE/N-1}$  : r.m.s. value of the fundamental oscillation of the phase voltage  
of outer conductor  $L = \{1, 2, 3\}$  to earth/neutral conductor

$I_{D-E/N}$  : distortion current earth/neutral conductor

where

E = earth (3-conductor system)

N = neutral conductor (4-conductor system)

## Dimensionless power measurement quantities

In general:

$\varphi_L$  : phase difference between the phase voltage and the conductor current (fundamental oscillation)

$\varphi_G$  : phase angle of the apparent power of the geometrical fundamental oscillation

The 150/180-period, 10-minute and 2-hour values are calculated from the corresponding val-

ues of the input quantities.

## Active factor

Phase:

$$PF_L = \frac{P_L}{S_L}$$

Collective:

$$PF_{\Sigma} = \frac{P_{\Sigma}}{S_{\Sigma}}$$

## COSPHI

Phase:

$$\text{COS}\varphi_L = \cos(\varphi_L)$$

Collective:

$$\text{COS}\varphi = \cos(\varphi_G)$$

Output of the COSPHI for analogue display devices:

The  $\text{COS}\varphi$  is mapped linearly in the range 0(cap.)...+1(ind.) or 0(cap.)...-1(ind.)  
to  $Y = -1(\text{cap.})...0...+1(\text{ind.})$  irrespective of the draw/supply.

Phase:

$$Y_L = \text{Sgn}(\varphi_L) \cdot (\text{Sgn}(\text{COS}\varphi_L) - \text{COS}\varphi_L)$$

Collective:

$$Y = \text{Sgn}(\varphi_G) \cdot (\text{Sgn}(\text{COS}\varphi) - \text{COS}\varphi)$$

$\text{COS}\varphi$  with sign of displacement angle (capacitive: -, inductive: +),  
irrespective of draw/supply :

Phase:

$$\text{COSPHV}_L = \text{Sgn}(\varphi_L) \cdot \text{COS}\varphi_L$$

Collective:

$$\text{COSPHV} = \text{Sgn}(\varphi_G) \cdot \text{COS}\varphi$$

Reactive factor

Phase:

$$QF_L = \frac{Q_L}{S_L}$$

Collective:

$$QF_\Sigma = \frac{Q_\Sigma}{S_\Sigma}$$

SINPHI

Phase:

$$SIN\varphi_L = \sin(\varphi_L)$$

Collective:

$$SIN\varphi = \sin(\varphi_G)$$

TANPHI

Phase:

$$TAN\varphi_L = \tan(\varphi_L)$$

$$TAN\varphi = \tan(\varphi_G)$$

Collective:

## Active energies

The active energies of the phases in a time interval defined by  $t_0$  (reset point) and  $t_m$  (measurement point) are calculated by summation of the products of the 10/12-period values of the active power and the associated 10/12-period time.

The 150/180-period, 10-minute and 2-hour values are taken from the corresponding accumulator at the relevant intervals and transferred in kWh.

$$W_L(t_0, t_m) = \sum_{n=0}^m P_{L-10/12}(n) \cdot T_{10/12}(n)$$

The relevant sum of the corresponding phase active energies is output as network active energy.

## Total active energy

All 10/12-period values of the active power of the phases are included in the summation, retaining their signs.

## Supplied active energy

Only the 10/12-period values of the active power of the phases with a positive sign are included in the summation.

## Drawn active energy

Only the 10/12-period values of the active power of the phases with a negative sign are included with a positive sign in the summation.

## Reactive energies

The reactive energies of the phases in a time interval defined by  $t_0$  (reset point) and  $t_m$  (measurement point) are calculated by summation of the products of the 10/12-period values of the reactive power and the associated 10/12-period time.

The 150/180-period, 10-minute and 2-hour values are taken from the corresponding accumulator at the relevant intervals and transferred in kVAh.

$$W_{r-L}(t_0, t_m) = \sum_{n=0}^m Q_{L-10/12}(n) \cdot T_{10/12}(n)$$

The relevant sum of the corresponding phase reactive energies is output as network reactive energy.

### Total reactive energy

All 10/12-period values of the reactive power of the phases are included in the summation, retaining their signs.

### Supplied reactive energy

Only the 10/12-period values of the reactive power of the phases with a positive sign are included in the summation.

### Drawn reactive energy

Only the 10/12-period values of the reactive power of the phases with a negative sign are included with a positive sign in the summation.

### Flicker magnitude

The short-term flicker magnitudes  $P_{st}$  (10 minutes) and long-term flicker magnitudes  $P_{lt}$  (2 hours) are calculated for the phase and delta voltages.  $P_{st}$  and  $P_{lt}$  are defined in EN 61000-4-15.

## Transnestic

---

If voltage dips or overvoltages occur, the PQI-DA generates events that allow conclusions to be drawn about the cause of the error (error type).

The trigger thresholds can be set.

Event value	Error type	Phase	Direction
1	Short-circuit	L1-E	behind measurement point (own network)
2	Short-circuit	L2-E	behind measurement point (own network)
3	Short-circuit	L1-L2	behind measurement point (own network)
4	Short-circuit	L3-E	behind measurement point (own network)
5	Short-circuit	L3-L1	behind measurement point (own network)
6	Short-circuit	L2-L3	behind measurement point (own network)
7	Short-circuit	L1-L2-L3	behind measurement point (own network)
9	Overvoltage	L1-E	behind measurement point (own network)
10	Overvoltage	L2-E	behind measurement point (own network)
11	Overvoltage	L1-L2	behind measurement point (own network)
12	Overvoltage	L3-E	behind measurement point (own network)
13	Overvoltage	L3-L1	behind measurement point (own network)
14	Overvoltage	L2-L3	behind measurement point (own network)
15	Overvoltage	L1-L2-L3	before measurement point
17	Short-circuit	L1-E	before measurement point
18	Short-circuit	L2-E	before measurement point
19	Short-circuit	L1-L2	before measurement point
20	Short-circuit	L3-E	before measurement point
21	Short-circuit	L3-L1	before measurement point
22	Short-circuit	L2-L3	before measurement point
23	Short-circuit	L1-L2-L3	before measurement point
25	Overvoltage	L1-E	before measurement point



26	Overvoltage	L2-E	before measurement point
27	Overvoltage	L1-L2	before measurement point
28	Overvoltage	L3-E	before measurement point
29	Overvoltage	L3-L1	before measurement point
30	Overvoltage	L2-L3	before measurement point
31	Overvoltage	L1-L2-L3	before measurement point

## Updating the firmware

Firmware updates can only be carried out via the COM1 interface of the device. The following steps are necessary:

- Establish a physical connection between the PC and the PQI-D via zero modem cable.
- The program “COMM.EXE” can be found in the “Firmware” subfolder, which is located in the WinPQ folder. To upload the new firmware, select a transfer speed of 115 baud at the RS232 interface of the PC and set the hardware protocol to “RTS/CTS”.
- Then switch the station to firmware upload mode by pressing and holding the reset button for at least 5 seconds. The following status LEDs light up when the button is released.

**PQI-D:** The service and notification LEDs are green; the fault LED is red.

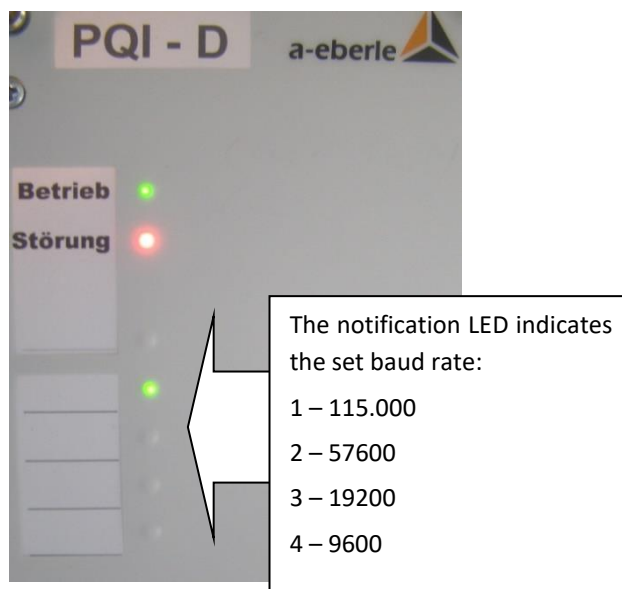

- In the program "COMM.EXE" menu: Select "Send terminal/firmware with reset".
- The familiar Windows "Open file dialog" is shown. The valid firmware file (e.g. PQI\_UU.MOT) must be opened.

The "Operation" LED flashes once per second during data transfer.

The status of the upload can be followed in the program status line.

- Then (transfer takes approx. 3 to 5 minutes), the device restarts. As soon as the "Operation" LED lights up again, it is possible to query the version at the terminal using the "VER" command. The response must contain the new firmware version with the associated date, e.g. "PQI-D: Version 5.0.09 from 13.01.11"
- You can use the terminal command "SYSRESET=590" to load the current factory settings. The station is then restarted. The station parameterisations are then restored via one of the communication interfaces using the "PQPara" program components.

## Maintenance and current consumption

### Changing the fuse



**Caution!** It is essential that the PQI-D be disconnected from the voltage supply before the fuse is changed!

**Required fuses:**

- H1: Microfuse (time-lag) T1 250 V, 1 A
- H2: Microfuse (time-lag) T2 250 V, 2 A

The fuse holder can be found on circuit board 2.

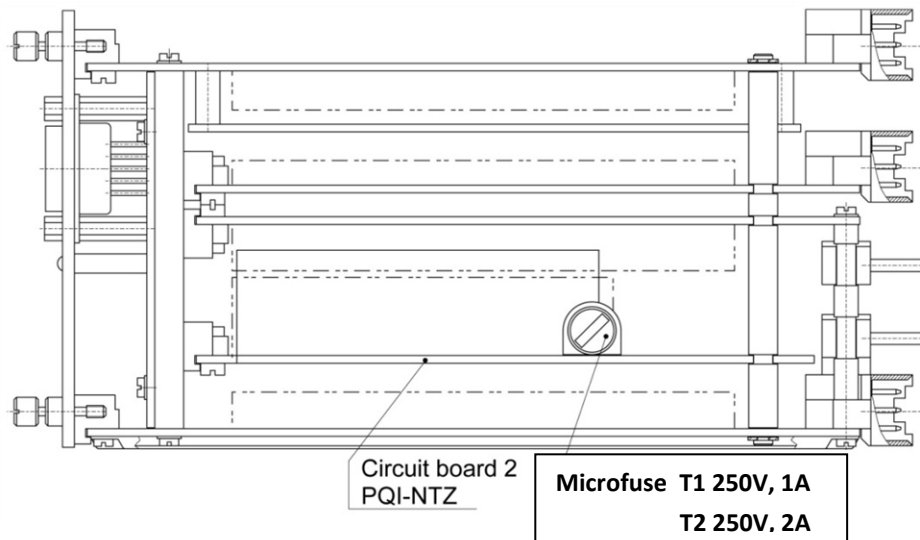

### Changing the battery



**Caution!** It is essential that the PQI-D be disconnected from the voltage supply before changing the battery!

All parameters are lost as soon as the battery is desoldered.

Use the vacant socket for newer batteries with connector plugs.

**Required battery:**

- Lithium 3 V with soldering lugs type CR1425050 from FDK

**Service life:**

- When stored for > 6 years
- When in operation with a switch-on duration of > 50% for > 10 years

We recommend having the battery changed at the factory.

## PQI-D current consumption

### Measurement results

Switch-on spike of 100 V DC

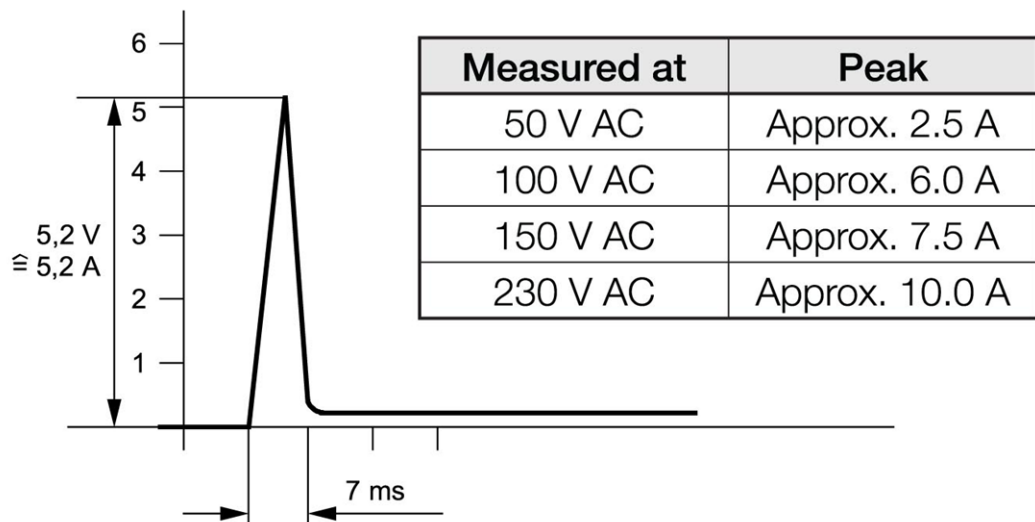

*The measurement values are intended as an aid to fuse selection.*

## Scope of delivery

---

- PQI-D corresponding to the design features
- Operating manual
- Supplement
- CD (operating manual, PQ Para Express software)  
Commissioning instructions

## Storage information

---

The devices should be stored in clean, dry rooms. The devices and their respective replacement modules can be stored between  $-25^{\circ}\text{C}$  and  $+65^{\circ}\text{C}$ .

The relative humidity must not lead to the formation of either condensation or ice.

We recommend that the storage temperature be kept between  $+0^{\circ}\text{C}$  and  $+55^{\circ}\text{C}$  to ensure that the built-in electrolytic capacitors do not age prematurely.

We also recommend that the device be connected to an auxiliary voltage every two years to reform the electrolytic capacitors. This procedure should also be carried out before the device is put into operation. Under extreme climatic conditions (tropics), this also ensures “pre-heating” at the same time and helps to avoid the formation of condensation.

The device should be stored in the service room for at least two hours prior to being connected to the voltage for the first time, so that it can become accustomed to the ambient temperature and to avoid the formation of moisture and condensation.

## Warranty

---

We guarantee that every product A. Eberle GmbH & Co KG is free from material and manufacturing defects under normal use.

The detailed conditions for the warranty can be found in our general terms and conditions of business under: <https://www.a-eberle.de/en/general-terms/>

## Ordering information

Please note the following when ordering:

- Only one code with the same capital letter is possible.
- If the capital letter is followed by the number 9, additional details in plain text are required.
- If capital letters are followed only by zeros, the code can be omitted.

FEATURE	CODE
Power quality interface for medium and high voltage networks <ul style="list-style-type: none"> <li>● according to DIN EN 50160 and IEC 61000-4-30</li> <li>● with two E-LAN interfaces for communication</li> <li>● with REGSys components REG-D(A), PAN-D, REG-DP(A), MMU-D, EOR-D and REG-DM.</li> </ul> The standard version is equipped with COM 1, COM 2 and COM 3	PQI-D
Design <ul style="list-style-type: none"> <li>● 19" plug-in module (18TE/3HE)</li> <li>● Wall mounting housing (20TE)</li> <li>● Panel mounting housing (30TE)</li> <li>● 19" frame or wall mounting housing (30TE, 49TE)</li> </ul> Wiring according to agreement	B01 B90 B91 B92
Supply voltage <ul style="list-style-type: none"> <li>● AC 100V ... 110V ... 240V / DC 100V..220V..300V</li> <li>● DC 20V...60V...70V</li> </ul>	H1 H2
Input configuration <ul style="list-style-type: none"> <li>● 4 voltage transformers</li> <li>● 2 x 4 voltage transformers</li> <li>● 4 voltage transformers, 4 current transformers <math>I_n = 1A (I_{max} &lt; 2 \times I_n)</math></li> <li>● 4 voltage transformers, 4 current transformers <math>I_n=1A (I_{max} &lt; 20 \times I_n)</math></li> <li>● 4 voltage transformers, 4 current transformers <math>I_n=5A (I_{max} &lt; 2 \times I_n)</math></li> <li>● 4 voltage transformers, 4 current transformers <math>I_n=5A (I_{max} &lt; 20 \times I_n)</math></li> <li>● 4 voltage transformers, 4 current inputs for Rogowski coils</li> <li>● 4 voltage transformers, 4 current inputs for mini current clamps</li> </ul>	C00 C10 C20 C21 C30 C31 C40 C41
Rated value of the input voltage <ul style="list-style-type: none"> <li>● 100 V / 110 V</li> <li>● 230 V / 400 V</li> </ul> other rated voltages (e.g. 4 x 100 V and 4 x 400 V)	E1 E2 E9
Additional inputs and outputs <ul style="list-style-type: none"> <li>● with 5 programmable relays plus life contact 16 programmable binary inputs (48...250 V AC/DC) (additional voltage ranges possible on request)</li> <li>● With 3 programmable relays plus life contacts 4 programmable mA outputs and 6 programmable binary inputs <b>Note:</b> Please specify the nominal voltage for the binary inputs!</li> <li>● with 7 programmable relays plus life contact</li> <li>● with 8 programmable mA outputs</li> <li>● with 6 analogue mA outputs and 2 binary outputs plus life contact</li> </ul>	M00  M92  M93 M94 M95

FEATURE	CODE
<ul style="list-style-type: none"> <li>with 5 relays plus life contact, 16 binary inputs for DC signals (48 V...250 V) with time stamp accuracy of +20 ms (additional voltage ranges possible on request)</li> </ul>	M96
<ul style="list-style-type: none"> <li>with one programmable relay contact (e.g. life contact) 16 programmable binary inputs (10 ... 50 V AC/DC) 4 analogue inputs (0... 10 V / 4 ... 20 mA)</li> </ul>	M97
<ul style="list-style-type: none"> <li>with one programmable relay contact (e.g. life contact) 16 programmable inputs (48 ... 250 V AC/DC) 4 analogue inputs (0 ... 10 V / 4 ... 20 mA)</li> </ul>	M98
Operating manual <ul style="list-style-type: none"> <li>German</li> <li>English</li> <li>French</li> </ul>	G1 G2 G3
Accessories for PQI-D	ID
Rogowski coil: Measurement range: 1 A to 2650 A, coil circumference: 61 cm with an 8 m long feeder cable	111.7009
Mini current clamp: Measurement range: 10 mA to 20 A, 10 m feeder cable with an 8 m long feeder cable	111.7010
100 MBit TCP/IP adaptor <ul style="list-style-type: none"> <li>can be installed on standard mounting rails with a power supply unit for Uh 230 V AC</li> <li>as an 8TE / 3HE plug-in module with power supply unit: 85 V AC ... 110 V ... 264 V AC / 88 V ... 220 V ... 280 V DC</li> <li>as an 8TE / 3HE plug-in module with power supply unit: 18 V ... 60 V ... 72 V DC</li> </ul>	REG-COM A01 A02 A03
DCF 77 radio clock	111.9024
GPS NIS Time radio clock <ul style="list-style-type: none"> <li>Supply voltage 85 V...264 V AC/DC</li> <li>Supply voltage 18 V...72 V DC</li> </ul>	111.9024.45 111.9024.46
RS 232 extension cable (10 m)	582.2040.10
USB adaptor for zero modem cable	111.9046
IRIG-DCF77 - converter (10 TE) <ul style="list-style-type: none"> <li>AC 100V ... 110V ... 240V / DC 100V..220V..300V</li> <li>DC 20V...60V...70V</li> <li>as a 10TE / 3HE plug-in module</li> <li>as a 20TE wall mounting housing</li> </ul>	IRIG-DCF H1 H2 B2 B1
Operating manual <ul style="list-style-type: none"> <li>German</li> <li>English</li> </ul>	G1 G2

## Software

Feature	ID
<b>WinPQ software</b> For parameterising, archiving and evaluating PQI-D/DA measurement data with the following basic functions:	WinPQ

We take care of it.

Feature	ID
<ul style="list-style-type: none"> <li>● 32-bit Windows program interface</li> <li>● SQL database for storage of measurement values for each measurement point data access via TCP/IP network</li> <li>● Option of displaying all measurement quantities that can be accessed by a PQI-D/DA as a function of time and as a statistical quantity</li> <li>● An additional workplace license is included in the price</li> </ul>	
<p><b>Licenses</b></p> <ul style="list-style-type: none"> <li>● As a single license for 2 PQI-Ds/PQI-DAs</li> <li>● As a single license for 2 to 10 PQI-Ds/PQI-DAs</li> <li>● As a single license for &gt; 10 PQI-Ds/PQI-DAs</li> <li>● Company licence</li> </ul>	<p>L0 L1 L2 L3</p>
<p><b>Language</b></p> <ul style="list-style-type: none"> <li>● German</li> <li>● English</li> </ul>	<p>A1 A2</p>
<p><b>Further WinPQ licenses</b> for up to three workplaces</p>	
<p><b>Software ParaPQ</b> (without database!) for parameterising PQI-Ds/PQI-DAs, as well as reading PQI-D/PQI-DA measurement data (free of charge)</p>	<p><b>PQ Para Express</b></p>







## A. Eberle GmbH & Co. KG

Frankenstraße 160  
90461 Nuremberg, Germany

Tel.: +49 (0) 911 / 62 81 08-0  
Fax: +49 (0) 911 / 62 81 08 96  
E-mail: [info@a-eberle.de](mailto:info@a-eberle.de)

<http://www.a-eberle.de>

Software version:

---

Version: 130703

Version: 02.05.2023 16:20